



AR-3000SD

AUDIO RECORDER

Owner's Manual

Before using the AR-3000SD, ensure that its system program is at the most recent version. For information on available upgrades for the system program, see the Roland website (<http://www.roland.com/support/>).

Roland

Owner's Manual (this document)

Read this first. It explains the basic things you need to know in order to use the AR-3000SD.



PDF Manual (download from the Web)

- **Reference Manual**
This describes all parameters of the AR-3000SD.
- **Command Reference Manual**
This describes control via the RS-232C interface, Telnet, or FTP.
- **ARE-3000 Manual**
This is the manual for the computer software (Windows only).

To obtain the PDF manual

1. Enter the following URL in your computer.
<http://www.roland.com/manuals/>
▼
2. Choose "AR-3000SD" as the product name.

WARNING: To reduce the risk of fire or electric shock, do not expose this apparatus to rain or moisture.

 CAUTION RISK OF ELECTRIC SHOCK DO NOT OPEN	
ATTENTION: RISQUE DE CHOC ELECTRIQUE NE PAS OUVRIR	
CAUTION: TO REDUCE THE RISK OF ELECTRIC SHOCK, DO NOT REMOVE COVER (OR BACK). NO USER-SERVICEABLE PARTS INSIDE. REFER SERVICING TO QUALIFIED SERVICE PERSONNEL.	



The lightning flash with arrowhead symbol, within an equilateral triangle, is intended to alert the user to the presence of uninsulated "dangerous voltage" within the product's enclosure that may be of sufficient magnitude to constitute a risk of electric shock to persons.



The exclamation point within an equilateral triangle is intended to alert the user to the presence of important operating and maintenance (servicing) instructions in the literature accompanying the product.

INSTRUCTIONS PERTAINING TO A RISK OF FIRE, ELECTRIC SHOCK, OR INJURY TO PERSONS.

IMPORTANT SAFETY INSTRUCTIONS SAVE THESE INSTRUCTIONS

WARNING - When using electric products, basic precautions should always be followed, including the following:

1. Read these instructions.
2. Keep these instructions.
3. Heed all warnings.
4. Follow all instructions.
5. Do not use this apparatus near water.
6. Clean only with a dry cloth.
7. Do not block any of the ventilation openings. Install in accordance with the manufacturers instructions.
8. Do not install near any heat sources such as radiators, heat registers, stoves, or other apparatus (including amplifiers) that produce heat.
9. Do not defeat the safety purpose of the polarized or grounding-type plug. A polarized plug has two blades with one wider than the other. A grounding type plug has two blades and a third grounding prong. The wide blade or the third prong are provided for your safety. If the provided plug does not fit into your outlet, consult an electrician for replacement of the obsolete outlet.
10. Protect the power cord from being walked on or pinched particularly at plugs, convenience receptacles, and the point where they exit from the apparatus.
11. Only use attachments/accessories specified by the manufacturer.
12. Unplug this apparatus during lightning storms or when unused for long periods of time.
13. Refer all servicing to qualified service personnel. Servicing is required when the apparatus has been damaged in any way, such as power-supply cord or plug is damaged, liquid has been spilled or objects have fallen into the apparatus, the apparatus has been exposed to rain or moisture, does not operate normally, or has been dropped.

For the U.K.

WARNING: THIS APPARATUS MUST BE EARTHED

IMPORTANT: THE WIRES IN THIS MAINS LEAD ARE COLOURED IN ACCORDANCE WITH THE FOLLOWING CODE.
GREEN-AND-YELLOW: EARTH, BLUE: NEUTRAL, BROWN: LIVE

As the colours of the wires in the mains lead of this apparatus may not correspond with the coloured markings identifying the terminals in your plug, proceed as follows:

The wire which is coloured GREEN-AND-YELLOW must be connected to the terminal in the plug which is marked by the letter E or by the safety earth symbol  or coloured GREEN or GREEN-AND-YELLOW.

The wire which is coloured BLUE must be connected to the terminal which is marked with the letter N or coloured BLACK.

The wire which is coloured BROWN must be connected to the terminal which is marked with the letter L or coloured RED.

Before using this unit, carefully read the sections entitled "IMPORTANT SAFETY INSTRUCTIONS" (p. 2), "USING THE UNIT SAFELY" (p. 3), and "IMPORTANT NOTES" (p. 5). These sections provide important information concerning the proper operation of the unit. Additionally, in order to feel assured that you have gained a good grasp of every feature of your new unit, read Owner's Manual in its entirety. This manual should be saved and kept on hand as a convenient reference.



Copyright © 2014 ROLAND CORPORATION

All rights reserved. No part of this publication may be reproduced in any form without the written permission of ROLAND CORPORATION.



USING THE UNIT SAFELY

INSTRUCTIONS FOR THE PREVENTION OF FIRE, ELECTRIC SHOCK, OR INJURY TO PERSONS

About ⚠ WARNING and ⚠ CAUTION Notices

 WARNING	Used for instructions intended to alert the user to the risk of death or severe injury should the unit be used improperly.
 CAUTION	Used for instructions intended to alert the user to the risk of injury or material damage should the unit be used improperly. * Material damage refers to damage or other adverse effects caused with respect to the home and all its furnishings, as well to domestic animals or pets.

About the Symbols

	The ⚠ symbol alerts the user to important instructions or warnings. The specific meaning of the symbol is determined by the design contained within the triangle. In the case of the symbol at left, it is used for general cautions, warnings, or alerts to danger.
	The ⓧ symbol alerts the user to items that must never be carried out (are forbidden). The specific thing that must not be done is indicated by the design contained within the circle. In the case of the symbol at left, it means that the unit must never be disassembled.
	The ● symbol alerts the user to things that must be carried out. The specific thing that must be done is indicated by the design contained within the circle. In the case of the symbol at left, it means that the power-cord plug must be unplugged from the outlet.

ALWAYS OBSERVE THE FOLLOWING

WARNING

Make sure that the power cord is grounded

Connect mains plug of this model to a mains socket outlet with a protective earthing connection.



To completely turn off power to the unit, pull out the plug from the outlet

Even with the power switch turned off, this unit is not completely separated from its main source of power. When the power needs to be completely turned off, turn off the power switch on the unit, then pull out the plug from the outlet. For this reason, the outlet into which you choose to connect the power cord's plug should be one that is within easy reach and readily accessible.



Concerning the Auto Off function

The power to this unit will be turned off automatically after a predetermined amount of time has passed since it was last used its buttons or controls were operated (Auto Off function). If you do not want the power to be turned off automatically, disengage the Auto Off function (p. 11).



Do not disassemble or modify by yourself

Do not carry out anything unless you are instructed to do so in the owner's manual. Otherwise, you risk causing malfunction.



Do not repair or replace parts by yourself

Refer all servicing to your retailer, the nearest Roland Service Center, or an authorized Roland distributor, as listed on the "Information."



WARNING

Do not use or store in the following types of locations

- Subject to temperature extremes (e.g., direct sunlight in an enclosed vehicle, near a heating duct, on top of heat-generating equipment); or are
- Damp (e.g., baths, washrooms, on wet floors); or are
- Exposed to steam or smoke; or are
- Subject to salt exposure; or are
- Exposed to rain; or are
- Dusty or sandy; or are
- Subject to high levels of vibration and shakiness.



Do not place in an unstable location

Otherwise, you risk injury as the result of the unit toppling over or dropping down.



Use only the supplied power cord

Use only the attached power cord. Also, the supplied power cord must not be used with any other device.



Connect the power cord to an outlet of the correct voltage

The unit should be connected to a power supply only of the type described in the operating instructions, or as marked on the side of unit.



Do not bend the power cord or place heavy objects on it

Otherwise, fire or electric shock may result.



WARNING

Avoid extended use at high volume

Use of the unit at high volume for extended periods of time may cause hearing loss. If you ever experience any hearing loss or ringing in the ears, you should immediately stop using the unit and consult a specialized physician.



Do not allow foreign objects or liquids to enter unit; never place containers with liquid on unit

Do not place containers containing liquid (e.g., flower vases) on this product. Never allow foreign objects (e.g., flammable objects, coins, wires) or liquids (e.g., water or juice) to enter this product. Doing so may cause short circuits, faulty operation, or other malfunctions.



Turn off the unit if an abnormality or malfunction occurs

Immediately turn the unit off, remove the power cord from the outlet, and request servicing by your retailer, the nearest Roland Service Center, or an authorized Roland distributor, as listed on the "Information" when:



- The power cord has been damaged; or
- If smoke or unusual odor occurs; or
- Objects have fallen into, or liquid has been spilled onto the unit; or
- The unit has been exposed to rain (or otherwise has become wet); or
- The unit does not appear to operate normally or exhibits a marked change in performance.

USING THE UNIT SAFELY

WARNING

Be cautious to protect children from injury

Always make sure that an adult is on hand to provide supervision and guidance when using the unit in places where children are present, or when a child will be using the unit.



Do not drop or subject to strong impact

Otherwise, you risk causing damage or malfunction.



Do not share an outlet with an unreasonable number of other devices

Otherwise, you risk overheating or fire.



Do not use overseas

Before using the unit in overseas, consult with your retailer, the nearest Roland Service Center, or an authorized Roland distributor, as listed on the "Information."



CAUTION

Place in a well ventilated location

The unit should be located so that its location or position does not interfere with its proper ventilation.



When disconnecting the power cord, grasp it by the plug

To prevent conductor damage, always grasp the power cord by its plug when disconnecting it from this unit or from a power outlet.



Periodically clean the power plug

An accumulation of dust or foreign objects between the power plug and the power outlet can lead to fire or electric shock.



At regular intervals, be sure to pull out the power plug, and using a dry cloth, wipe away any dust or foreign objects that may have accumulated.

Disconnect the power plug whenever the unit will not be used for an extended period of time

Fire may result in the unlikely event that a breakdown occurs.



Route all power cords and cables in such a way as to prevent them from getting entangled

Injury could result if someone were to trip on a cable and cause the unit to fall or topple.



Avoid climbing on top of the unit, or placing heavy objects on it

Otherwise, you risk injury as the result of the unit toppling over or dropping down.



Never connect/disconnect a power plug if your hands are wet

Otherwise, you could receive an electric shock.



Disconnect all cords/cables before moving the unit

Before moving the unit, disconnect the power plug from the outlet, and pull out all cords from external devices.



Before cleaning the unit, disconnect the power plug from the outlet

If the power plug is not removed from the outlet, you risk receiving an electric shock.



CAUTION

Whenever there is a threat of lightning, disconnect the power plug from the outlet

If the power plug is not removed from the outlet, you risk receiving an electric shock.



Keep small items out of the reach of children

To prevent accidental ingestion of the parts listed below, always keep them out of the reach of small children.



- Included Parts
 - Rubber feet (p. 10)
 - Screws (p. 10)
 - Card protector (p. 10)
- Removable Parts
 - Screws (p. 10)

Handle the ground terminal carefully

If you remove the screw from the ground terminal, be sure to replace it; don't leave it lying around where it could accidentally be swallowed by small children. When refastening the screw, make that it is firmly fastened, so it won't come loose.



IMPORTANT NOTES

Power Supply

- Do not connect this unit to same electrical outlet that is being used by an electrical appliance that is controlled by an inverter or a motor (such as a refrigerator, washing machine, microwave oven, or air conditioner). Depending on the way in which the electrical appliance is used, power supply noise may cause this unit to malfunction or may produce audible noise. If it is not practical to use a separate electrical outlet, connect a power supply noise filter between this unit and the electrical outlet.

Placement

- Using the unit near power amplifiers (or other equipment containing large power transformers) may induce hum. To alleviate the problem, change the orientation of this unit; or move it farther away from the source of interference.
- This unit may interfere with radio and television reception. Do not use this unit in the vicinity of such receivers.
- Noise may be produced if wireless communications devices, such as cell phones, are operated in the vicinity of this unit. Such noise could occur when receiving or initiating a call, or while conversing. Should you experience such problems, you should relocate such wireless devices so they are at a greater distance from this unit, or switch them off.
- Do not expose the unit to direct sunlight, place it near devices that radiate heat, leave it inside an enclosed vehicle, or otherwise subject it to temperature extremes. Excessive heat can deform or discolor the unit.
- When moved from one location to another where the temperature and/or humidity is very different, water droplets (condensation) may form inside the unit. Damage or malfunction may result if you attempt to use the unit in this condition. Therefore, before using the unit, you must allow it to stand for several hours, until the condensation has completely evaporated.
- Depending on the material and temperature of the surface on which you place the unit, its rubber feet may discolor or mar the surface. You can place a piece of felt or cloth under the rubber feet to prevent this from happening. If you do so, please make sure that the unit will not slip or move accidentally.
- Do not place containers or anything else containing liquid on top of this unit. Also, whenever any liquid has been spilled on the surface of this unit, be sure to promptly wipe it away using a soft, dry cloth.

Maintenance

- For everyday cleaning wipe the unit with a soft, dry cloth or one that has been slightly dampened with water. To remove stubborn dirt, use a cloth impregnated with a mild, non-abrasive detergent. Afterwards, be sure to wipe the unit thoroughly with a soft, dry cloth.
- Never use benzene, thinners, alcohol or solvents of any kind, to avoid the possibility of discoloration and/or deformation.

Repairs and Data

- Before sending the unit away for repairs, be sure to make a backup of the data stored within it; or you may prefer to write down the needed information. Although we will do our utmost to preserve the data stored in your unit when we carry out repairs, in some cases, such as when the memory section is physically damaged, restoration of the stored content may be impossible. Roland assumes no liability concerning the restoration of any stored content that has been lost.

Additional Precautions



- Any data stored within the unit can be lost as the result of equipment failure, incorrect operation, etc. To protect yourself against the irretrievable loss of data, try to make a habit of creating regular backups of the data you've stored in the unit.
- Roland assumes no liability concerning the restoration of any stored content that has been lost.
- Use a reasonable amount of care when using the unit's buttons, sliders, or other controls; and when using its jacks and connectors. Rough handling can lead to malfunctions.
- Never strike or apply strong pressure to the display.
- When disconnecting all cables, grasp the connector itself—never pull on the cable. This way you will avoid causing shorts, or damage to the cable's internal elements.
- A small amount of heat will radiate from the unit during normal operation.
- To avoid disturbing others nearby, try to keep the unit's volume at reasonable levels.
- When you need to transport the unit, pack it in shock-absorbent material. Transporting the unit without doing so can cause it to become scratched or damaged, and could lead to malfunction.

Using External Memories

- Please observe the following precautions when handling external memory devices. Also, make sure to carefully observe all the precautions that were supplied with the external memory device.
 - Do not remove the device while reading/writing is in progress.
 - To prevent damage from static electricity, discharge all static electricity from your person before handling the device.

Intellectual Property Right

- It is forbidden by law to make an audio recording, video recording, copy or revision of a third party's copyrighted work (musical work, video work, broadcast, live performance, or other work), whether in whole or in part, and distribute, sell, lease, perform, or broadcast it without the permission of the copyright owner.
- Do not use this product for purposes that could infringe on a copyright held by a third party. We assume no responsibility whatsoever with regard to any infringements of third-party copyrights arising through your use of this product.

- MMP (Moore Microprocessor Portfolio) refers to a patent portfolio concerned with microprocessor architecture, which was developed by Technology Properties Limited (TPL). Roland has licensed this technology from the TPL Group.
- Roland Corporation is an authorized licensee of the CompactFlash™ and CF  trademarks.
- MPEG Layer-3 audio compression technology is licensed from Fraunhofer IIS Corporation and THOMSON Multimedia Corporation.
- The SD logo () and SDHC logo () are trademarks of SD-3C, LLC.
- This product is using the open source license (GPL/LGPL) software. You have the right to acquire, modify and distribute the source code for this open source license software. You can obtain the open source license source code used in this product by downloading it from the following website:
URL: <http://www.roland.com/support/gpl/>
- © Copyright 2000-2001 /efont/ The Electronic Font Open Laboratory. All rights reserved.

Redistribution and use in source and binary forms, with or without modification, are permitted provided that the following conditions are met:

1. Redistributions of source code must retain the above copyright notice, this list of conditions and the following disclaimer.
2. Redistributions in binary form must reproduce the above copyright notice, this list of conditions and the following disclaimer in the documentation and/or other materials provided with the distribution.
3. Neither the name of the team nor the names of its contributors may be used to endorse or promote products derived from this font without specific prior written permission.

THIS FONT IS PROVIDED BY THE TEAM AND CONTRIBUTORS "AS IS" AND ANY EXPRESS OR IMPLIED WARRANTIES, INCLUDING, BUT NOT LIMITED TO, THE IMPLIED WARRANTIES OF MERCHANTABILITY AND FITNESS FOR A PARTICULAR PURPOSE ARE DISCLAIMED. IN NO EVENT SHALL THE TEAM OR CONTRIBUTORS BE LIABLE FOR ANY DIRECT, INDIRECT, INCIDENTAL, SPECIAL, EXEMPLARY, OR CONSEQUENTIAL DAMAGES (INCLUDING, BUT NOT LIMITED TO, PROCUREMENT OF SUBSTITUTE GOODS OR SERVICES; LOSS OF USE, DATA, OR PROFITS; OR BUSINESS INTERRUPTION) HOWEVER CAUSED AND ON ANY THEORY OF LIABILITY, WHETHER IN CONTRACT, STRICT LIABILITY, OR TORT (INCLUDING NEGLIGENCE OR OTHERWISE) ARISING IN ANY WAY OUT OF THE USE OF THIS FONT, EVEN IF ADVISED OF THE POSSIBILITY OF SUCH DAMAGE.

- Roland is an either registered trademark or trademark of Roland Corporation in the United States and/or other countries.
- Company names and product names appearing in this document are registered trademarks or trademarks of their respective owners.

Contents

IMPORTANT SAFETY INSTRUCTIONS	2
USING THE UNIT SAFELY	3
IMPORTANT NOTES	5
Main Features	7
Panel Descriptions	8
Front Panel	8
Rear Panel.....	9
Installation	10
Attaching the Rubber Feet.....	10
Rack Mounting (Important Notes on Heat Radiation).....	10
Attaching the Card Protector	10
Turning the Unit On and Off	11
Turning On the Unit	11
Setting the Time and Date.....	11
Turning Off the Unit	11
Examples of Usage and Connection for the AR-3000SD	12
Together with Other Equipment (System Examples).....	12
Using the Control Input and Output Terminals.....	12
Using the MIDI Connectors.....	12
Using the RS-232C Connector and LAN Port	13
Programmable Timers.....	13
Connections (Connection Methods)	13
Dual Mono Mode	13
What You Can Do (Usage Tips)	13
Repeat Playback of the Same Phrase.....	13
Playing a Variety of Phrases in Succession.....	13
Cards Compatible with the AR-3000SD	14
Types of Usable Cards	14
Card Storage Times and Number of Phrases.....	14
Formatting a Card	14
Important Notes on Handling Cards	15
Card Compatibility with Other Models in the AR Series... 15	
Using Cards Formatted on Earlier Model Units with the AR-3000SD.....	15
Using Cards Formatted on the AR-3000SD with Earlier Models.....	15
Important Note: About Setting Information Imported from a Card.....	16
Information Recorded on the Card	16
About the Display	17
Viewing the Basic Screen	17
Screen During Audio Phrase Playback	17
Screen During MIDI Phrase Playback.....	17
Screen During Pattern Phrase or Song Phrase Playback.....	17
Phrase Parameters List Screen	17
Display-Related Settings.....	18
Adjusting the Contrast	18
Making the Display Go Dark.....	18
Recording Audio	19
Recording Units (Phrases).....	19
Connecting Equipment.....	19
Procedure for Recording.....	19
Enabling Recording Standby	19
Required Settings for Recording Audio Signals (Recording Settings)	20
Starting and Ending Recording	21
Checking What You Recorded.....	21
Playback Using the Panel on the Unit (Manual Playback) ... 22	
Keeping the Output Volume Unchanged (Output Volume Thru)	22
Procedure for Making the Output Volume Thru Setting.....	22
Troubleshooting	23
Error Messages	25
Cards	26
Card-Specific Audio Recording Time Chart	26
Terminals	27
Specifications of the Control Input/Output Terminals	27
RS-232C Connector Specifications	28
Specification	29
Dimensions	30
Index	31

Main Features

High-Quality Recording and Playback

The AR-3000SD can perform linear recording and playback with high-quality 24-bit sound at 96 kHz. It supports MP3 as well, and is also capable of lengthy recording and playback.

What's more, it can play data created on earlier AR series units. Recorded content and settings are all stored on memory cards, so you can set up for different production scenarios rapidly by changing cards.

Audio Recording System with No Moving Parts

The AR-3000SD employs an audio recording system using CF and SD memory cards and has no moving parts.

This design requiring no mechanical maintenance ensures outstanding durability with no drop in sound quality.

A Variety of Control Jacks for a Wide Range of Playback Methods

The unit features a LAN port, an RS-232C port, MIDI connectors, and a control input connector as connectors for control use.

You can choose from among a variety of playback methods and system configurations to match the application and circumstances.

LAN Port

A LAN port is standard. This enables use of a wide variety of types of control, including recording and playback control via Telnet, using FTP to change phrases, monitoring operation and changing settings by means of a web browser, and setting the time by syncing with a time server.

Programmable Timers

The AR-3000SD has calendar and clock functionality built in.

This lets you create weekly and yearly schedules for program playback with no need for any extra equipment.

Two-Unit Playback with a Single Unit—Dual Mono Mode

The AR-3000SD features a Dual Mono mode that lets you manipulate the left and right channels independently, and play back monaural audio phrases individually.

You can play different phrases on the left and right channels, either simultaneously or in a staggered fashion.

MIDI Connectors Allow for Play of Musical Instruments and Syncing with Video

The AR-3000SD is equipped with MIDI connectors and can record and play SMF data. Control for recording and playback according to MIDI signals is also supported.

This makes possible such operations as recording and playback synced to external equipment through use of MTC and MMC signals.

Panel Descriptions

Front Panel

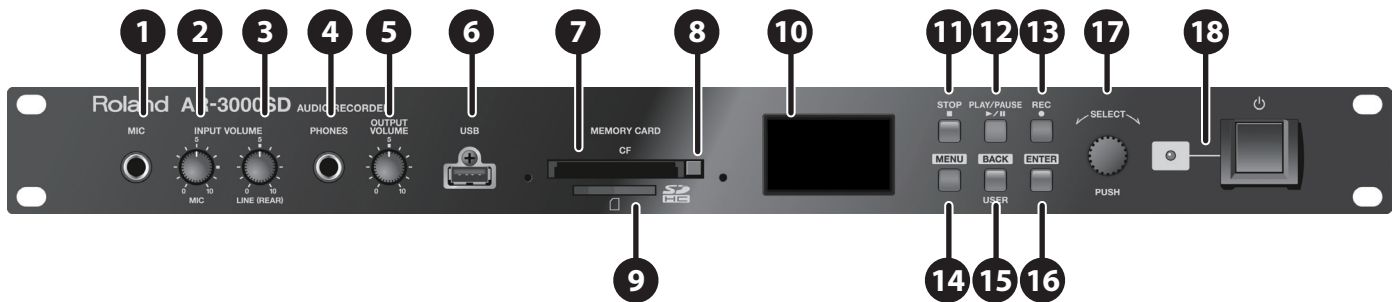

1 MIC jack

This is for connecting a microphone during audio recording.

2 INPUT VOLUME [MIC] knob

This adjusts the volume level of audio input from the microphone.

3 INPUT VOLUME [LINE] (REAR) knob

This adjusts the volume level of signals input via the LINE IN jacks on the rear panel.

4 PHONES jack

This is for connecting headphones for monitoring recording and playback. To adjust the volume level for headphones, you use the [OUTPUT VOLUME] knob.

When you activate the Output Vol. Thru feature (p. 22), you can use the [OUTPUT VOLUME] knob to adjust the headphones volume even when the [OUTPUT VOLUME] knob has been deactivated.

5 [OUTPUT VOLUME] knob

This adjusts the volume level of analog audio output. To prevent incorrect operation, the unit is provided with a Output Vol. Thru feature (p. 22) that lets you disable this knob and sets the volume at a fixed level.

6 USB port

Connecting a USB flash drive makes it possible to copy phrases between the flash drive and a CF card or SD card. You can also attach a USB keyboard or numeric keypad and use it to control phrase playback.

* Playback from or recording to a USB flash drive are not possible.

7 CF card slot

This is the slot for inserting a CF card.

8 CF card eject button

9 SD/SDHC memory card slot

This is the slot for inserting an SD card.

10 Display

→ "Viewing the Basic Screen" (p. 17)

11 [STOP] button

This stops playback or recording.

12 [PLAY/PAUSE] button (PLAY/PAUSE indicator)

This starts and pauses playback or recording.

13 [REC] button (REC indicator)

Pressing the [REC] button while stopped puts the unit in recording standby.

14 [MENU] button (MENU indicator)

This enters the various setting menus. The MENU indicator lights up while settings are being made.

15 [BACK] (USER) button

At a setting menu, this returns the entry location (highlighted) to the previous location.

At screens other than setting menus, you can specify a specific function for this button.

16 [ENTER] button

17 [SELECT] dial

This is used for such operations as selecting phrases and choosing setting items.

18 Power indicator, [⏻] switch

This turns the power to the AR-3000SD on and off. The indicator lights up when the power comes on.

About when the indicators light/flash

State	PLAY indicator	REC indicator
Stopped	Extinguished	Extinguished
Playback	Lights	Extinguished
Pause (Playback)	Flashes	Extinguished
Recording Standby	Extinguished	Flashes
Recording	Lights	Lights
Pause (Recording)	Flashes	Flashes
Playback standby (*1)	Flashes rapidly	Extinguished
Recording standby (*1)	Extinguished	Flashes rapidly

*1 When Sync Source is set to MTC

Rear Panel

* To prevent malfunction and equipment failure, always turn down the volume, and turn off all the units before making any connections.

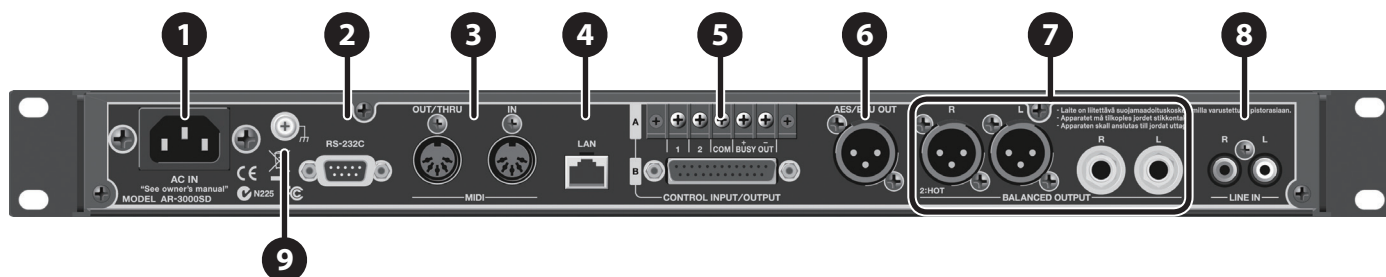

1 AC inlet

This is for connecting the included power cord.

2 RS-232C connector

This is used when connecting the AR-3000SD to a computer or the like for exchanging signals.

3 MIDI connectors (OUT/THRU, IN)

You use these for such operations as recording and playback of MIDI phrases and MIDI control of external devices. The MIDI OUT/THRU connector doubles in use as a MIDI Out and MIDI Thru connector. When shipped from the factory, the connector is set to "OUT." You can change this to "THRU" when necessary.

4 LAN port

This is for connecting a computer or other network-capable equipment.

5 CONTROL INPUT/OUTPUT terminals

These are used for connecting to external control devices. These also perform monaural analog audio output.

6 AES/EBU OUT jack

This outputs digital audio.

7 BALANCED OUTPUT jacks

These output analog audio.

They are used for connection to a power amp or the like. Both balanced and unbalanced connections are possible.

Balanced connections are recommended. When making an unbalanced connection, connect to cold and ground.

8 LINE IN jacks

These are for input of line-level analog audio.

* When connection cables with resistors are used, the volume level of equipment connected to the LINE IN jacks may be low. If this happens, use connection cables that do not contain resistors.

9 Ground terminal

You use this to connect the AR-3000SD to an electrical ground.

* Depending on the circumstances of a particular setup, you may experience a discomforting sensation, or perceive that the surface feels gritty to the touch when you touch this device, microphones connected to it, or the metal portions of other objects, such as guitars. This is due to an infinitesimal electrical charge, which is absolutely harmless. However, if you are concerned about this, connect the ground terminal with an external ground. When the unit is grounded, a slight hum may occur, depending on the particulars of your installation. If you are unsure of the connection method, contact the nearest Roland Service Center, or an authorized Roland distributor, as listed on the "Information" page.

Unsuitable places for connection

- Water pipes (may result in shock or electrocution)
- Gas pipes (may result in fire or explosion)
- Telephone-line ground or lightning rod (may be dangerous in the event of lightning)

MEMO

This instrument is equipped with balanced (XLR/TRS) type jacks. Wiring diagrams for these jacks are shown below. Make connections after first checking the wiring diagrams of other equipment you intend to connect.

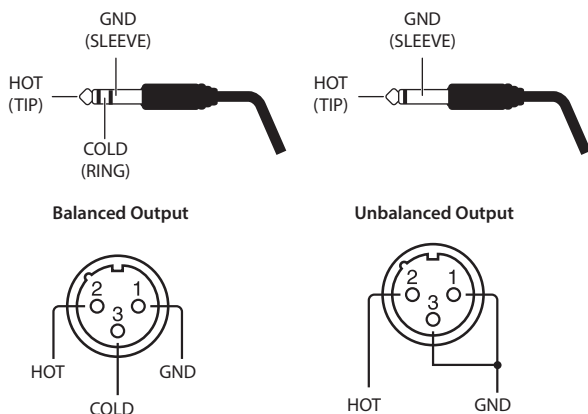

Installation

Attaching the Rubber Feet

Attach these as required, such as when you're using the AR-3000SD without mounting it on a rack or the like.

Peel off the double-sided tape from the rubber feet and affix the rubber feet at the locations shown in the following figure.

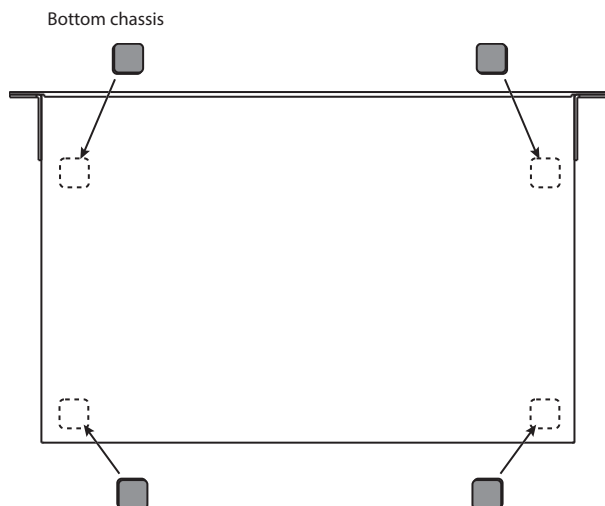

Rack Mounting (Important Notes on Heat Radiation)

When you are mounting the unit on a rack or the like, give attention to the following points to ensure efficient cooling.

- Install in a well-ventilated location.
- Avoid mounting in a sealed rack. Warm air within the rack cannot escape and is sucked into the unit again, making efficient cooling impossible.
- When you are using a stacked mounting arrangement, be especially sure to provide for adequate ventilation within the rack to keep discharged air from being sucked back into the unit. If the back surface of the rack cannot be kept open, then provide a ventilation port or ventilation fan at the upper area of the back surface of the rack, where warm air accumulates.
- When you are using the unit in a portable case or rack, remove the covers from the front and back surfaces of the case, so that the front and back surfaces of the unit are not obstructed.

* When placing the unit on the rack, be careful not to pinch your fingers.

* For more information about installation, also see "Placement" in the Important Notes (p. 5).

Attaching the Card Protector

By attaching the Card Protector (supplied) to the AR-3000SD, you can prevent the memory card from inadvertently being removed from the AR-3000SD.

1. Make sure that the card is securely inserted into the card slot.
2. Using the included screws, secure the card protector in place as shown in the figure.

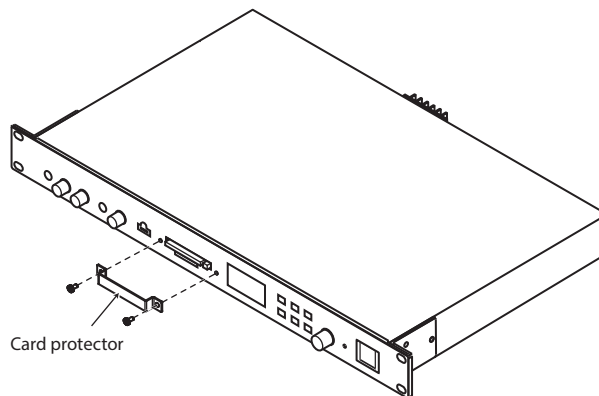

Turning the Unit On and Off

Turning On the Unit

- * Once everything is properly connected, be sure to follow the procedure below to turn on their power. If you turn on equipment in the wrong order, you risk causing malfunction or equipment failure.
- * This unit is equipped with a protection circuit. A brief interval (a few seconds) after turning the unit on is required before it will operate normally.
- * Before turning the unit on/off, always be sure to turn the volume down. Even with the volume turned down, you might hear some sound when switching the unit on/off. However, this is normal and does not indicate a malfunction.

Power on your equipment as described in the following. After the devices are turned on, set the volumes to each connected devices equipment.

Connected devices → AR-3000SD → Power Amplifier etc.

1. Confirm the volume levels on the AR-3000SD and any amp or mixer that is connected turned down to the lowest settings.
2. Press the [⏻] switch to turn on the unit.

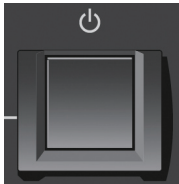

NOTE

To avoid risk of electric shock, do not touch the connectors while the unit is in operation.

3. Watch the display.



* This display is only an example for illustrative purposes, The content of the display will differ depending on the card settings.

Setting the Time and Date

When you turn on the power for the first time, follow the procedure below to set the internal clock.

1. Press the [MENU] button.
The MENU indicator lights up.
2. Use the [SELECT] dial to choose "11.4 Date/Time," then press the dial.
"HOUR" is selected.
3. Turn the [SELECT] dial to change the value of the "HOUR" setting.
4. Pressing the [SELECT] dial sequentially selects hour, minute, second, year, month, and day.
Pressing the [BACK] button returns the selection of hour, minute, second, year, month, or day to the previous item. Change the value of the setting selected using the [SELECT] dial.
5. To apply the time and date settings, press the [ENTER] button.
Pressing the [MENU] button without pressing the [ENTER] button makes a confirmation screen appear. To apply the settings, press the [ENTER] button.
To quit without making the settings, use the [SELECT] dial to choose "NO," then press the [ENTER] button.
When you're finished making the setting, the display returns to the setting item selection screen.
6. Press the [MENU] button.
This ends the setting process and returns you to the usual screen.

Turning Off the Unit

1. Confirm the volume levels on the AR-3000SD and any amp or mixer that is connected are turned down to the lowest settings.
2. Switch off the power of the device in the reverse order of that used to switch on the unit.
The display and each indicator will go dark, indicating that the power has been turned off.
 - * If you need to turn off the power completely, first turn off the unit, then unplug the power cord from the power outlet. Refer to "To completely turn off power to the unit, pull out the plug from the outlet" (p. 3).

If you don't want the power to turn off automatically, change the "Auto Off" setting to "Off"

The power to this unit will be turned off automatically after a predetermined amount of time has passed since it was last used for playing back, or its buttons or controls were operated (Auto Off function). If you do not want the power to be turned off automatically, disengage the Auto Off function.



NOTE

- Any settings that you are in the process of editing will be lost when the power is turned off. If you have any settings that you want to keep, you should save them beforehand.
- To restore power, turn the power on again.

MEMO

The Auto Off function is disabled when the card is inserted to the slot.

Disabling the auto off function

1. Press the [MENU] button.
The MENU indicator lights up.
2. Use the [SELECT] dial to choose "11.1 Auto Off," then press the dial.
3. Turn the [SELECT] dial to choose Auto Off (OFF), then press the dial.
4. When the prompt appears on the screen, press the [ENTER] button to enable the settings.
To quit without making the settings, use the [SELECT] dial to choose "NO," then press the [ENTER] button.
When you're finished making the setting, the display returns to the setting item selection screen.
5. Press the [MENU] button.
This ends the setting process and returns you to the usual screen.

Examples of Usage and Connection for the AR-3000SD

You can use the AR-3000SD alone or in combination with other AR-3000SD units or other equipment to play audio in a wide variety of scenes. This section shows some examples of these. You can use these examples as a starting point for making changes to match your own usage circumstances.

Together with Other Equipment (System Examples)

Using the Control Input and Output Terminals

Control input

Messages, explanations, warnings, announcements, effect sounds, and the like are played with high sound quality according to control signals from sensors, buttons, and switches.

● Momentary switch

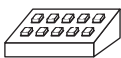

Pressing the switch plays back a set announcement, guidance message, explanation, or the like

- Broadcast of museum exhibition explanations or guidance
- Set announcements played back as required

● Sensor

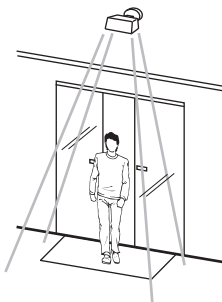

- Sensor-triggered automatic broadcasts
- Guidance announcements made upon detection of a person's presence
 - Playback of event performances at attractions and other sites

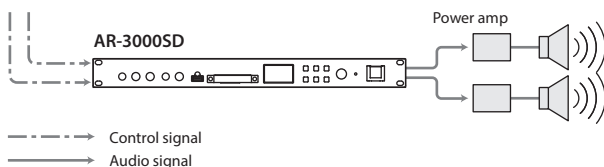

Control output

Control signals can be output during or after phrase playback to control an external device.

● Busy out

- Only during phrase playback, power amp or other gear is powered up (delay time set to five seconds)
- Lamp lights during phrase playback

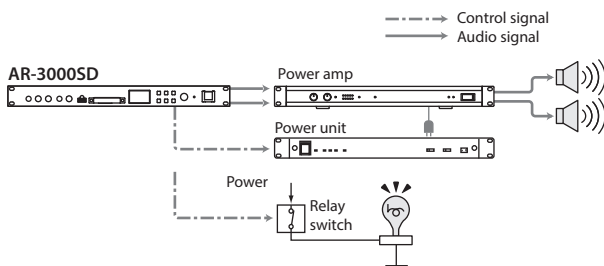

● Control out

After playback ends, controls external device

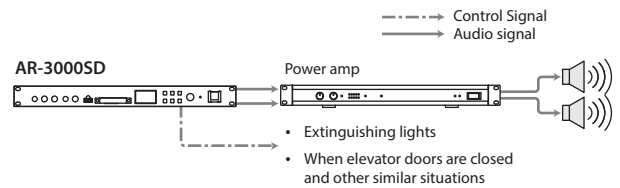

Using the MIDI Connectors

● Spatial expression

With the AR-3000SD serving as the master, the MIDI signals it sends out can be used to get a sound module to play background music. Or, you can have sound-effect phrases be played by a slaved AR-3000SD.

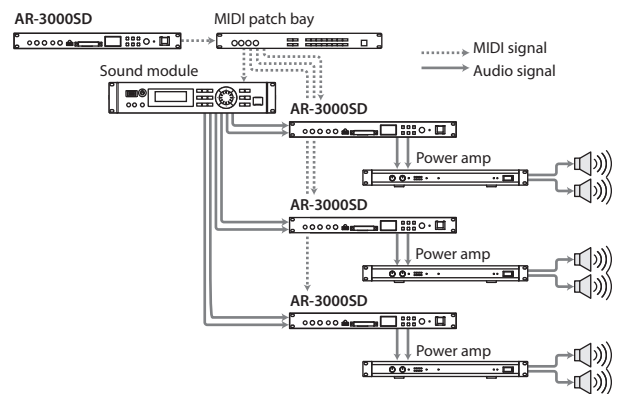

● Sound-field control

Using batch MIDI control from a switch box, you can change programs on a mixer, equalizer, or the like to control the sonic field.

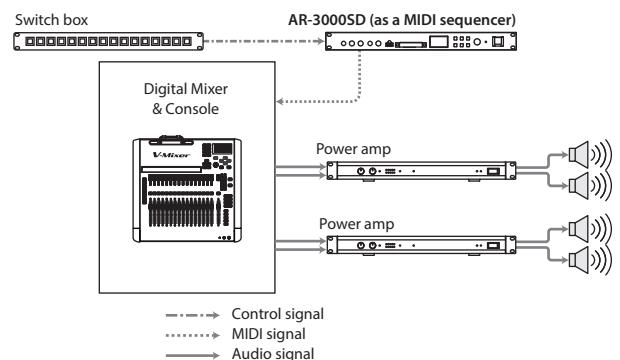

Using the RS-232C Connector and LAN Port

Using the RS-232C connector or the LAN port, you can control the AR-3000SD from a computer, touch panel, or other external control device.

● AR control with a computer

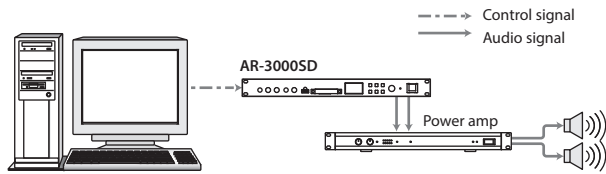

● Explanatory messages and guidance for public facilities and museum exhibits

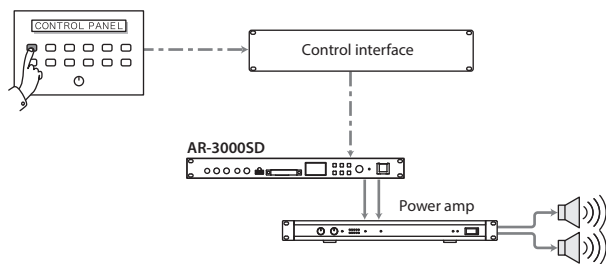

Programmable Timers

- Playing identification broadcasts and announcements at set times in offices and factories
- Production broadcasts for set-time events at amusement venues and more

Connections (Connection Methods)

Dual Mono Mode

The Dual Mono mode is a feature for playing different mono audio phrases independently on the left and right channels.

This lets you use the unit to play two units' worth of data.

You can also play back separate phrases on the left and right channels simultaneously, or control them individually.

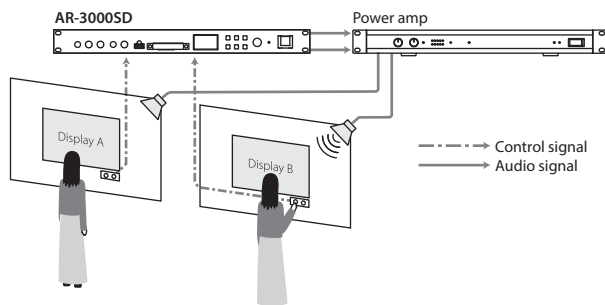

What You Can Do (Usage Tips)

Repeat Playback of the Same Phrase

Setting the phrase information for repeat play

You can repeat each individual phrase.

You can also do repeat play for a phrase combination (a group of phrases).

Inputting a continuous make-contact signal to the control input terminals

You can repeat playback by continuously shorting the control input terminals.

MEMO

With some settings, playback doesn't repeat even when you continuously input a make-contact signal. For details, refer to "Reference Manual" (PDF).

Playing a Variety of Phrases in Succession

Using phrase combinations

This continuously plays back stored phrases in succession.

Using direct playback of control input

By inputting control signals to a port number from 1 through 16, you can play back the phrase assigned to the number.

Using program playback of control input

This successively plays back phrases in preset sequence each time a control signal is input to the START port.

Using binary playback of control input

You select phrases by inputting binary signals to the phrase bit 0 through 9 connectors and the card bit 0 and 1 connectors, and play the selected phrases in succession by each time you input control signals to the START port.

Using the programmable timer feature

This plays phrases at preset times.

Cards Compatible with the AR-3000SD

Types of Usable Cards

The AR-3000SD stores recorded audio and MIDI signals on the card. Phrase setting data, system setting data, and other such information is also stored on the card, and not in the AR-3000SD itself.

This means that you can change the AR-3000SD's settings simply by swapping cards.

NOTE

- Be sure to use an optional CF card (CF-512, CF-01G, etc.) or SD card (SD-04G, etc.) as the card for the AR-3000SD. Using cards other than these might impede normal recording or playback due to factors such as data-write speed. For information on optional CF and SD cards, contact the vendor where you purchased the AR-3000SD.
- Information cannot be stored in memory in the AR-3000SD unit itself, so be sure to purchase cards separately.

MEMO

By using AR card data editor ARE-3000, all the data in a card can be backed up in your computer. When you restore backed up data to a card, please be sure to use the card formatted by the AR-3000SD.

Please download the ARE-3000 (free of charge) from the following URL.

<http://www.roland.com/support/>

Card Storage Times and Number of Phrases

You can create up to 2,000 phrases on a single card.

When you format a card, you preselect 250, 500, 1000, or 250 x 2, 500 x 2, 1000 x 2 as the maximum number of phrases to record on the card.

NOTE

After formatting, you cannot change the maximum number of phrases. Please be aware that changing the maximum number of phrases requires reformatting, which erases everything stored on the card.

MEMO

The possible recording time of a card varies according to card capacity and recording settings.

Depending on the length of stored phrases, creating the set maximum number of phrases might not be possible.

For details, refer to "Card-Specific Audio Recording Time Chart" (p. 26).

Formatting a Card

Before you can use a new card, you must first format (initialize) the card. Once the formatting is complete, you can give the card a name (using up to eight characters). When you record a phrase, this card name is automatically added to the beginning of the phrase name.

Example: Card name: MESSAGE → Phrase name: MESSAGE 1

If you don't give the card a name, the name "AR-3000" is used.

Important Note About Formatting

- Formatting erases all data on the card. Before you format a card, make certain it does not contain any important data.
- Do not format cards on a computer.

Notes About Formatting

- The time required for formatting a card varies with the card's capacity, and may last from several seconds to more than about ten seconds.
- For the maximum recording times available at each setting, refer to the "Card-Specific Audio Recording Time Chart" (p. 26).
- Depending on the length of stored phrases, creating the set maximum number of phrases might not be possible.
- For information about the initial values of various settings when formatted, refer to the "Reference Manual" (PDF).

Procedure for formatting a card

1. Make sure no card are inserted into the card slot, then switch on the unit.
2. Insert the card you want to format into the card slot.
3. Press the [MENU] button.
The MENU indicator lights up.
4. Use the [SELECT] dial to choose "4.1 Card Format," then press the dial.
5. Turn the [SELECT] dial to choose the card you want to format (CF or SD), then press the dial.

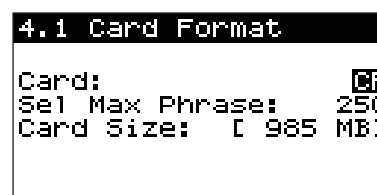

6. Turn the [SELECT] dial to choose the maximum number of phrases that can be recorded on the card (250, 500, 1000, or 250 x 2, 500 x 2, 1000 x 2), then press the dial.
7. When the prompt appears on the screen, press the [ENTER] button to format the card.

To quit without formatting, use the [SELECT] dial to choose "NO," then press the [ENTER] button.

NOTE

Never attempt to remove the card while formatting is in progress.

Important Notes on Handling Cards

When inserting

- Carefully insert the USB flash drives, CF cards, and SD cards all the way in—until it is firmly in place.
- Insert CF cards face-up into the card slot.
- Insert SD cards face-down into the card slot.

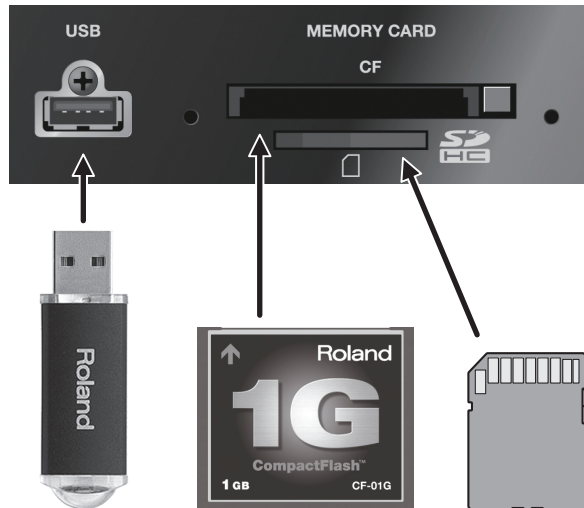

When removing

- To remove a CF card, press the CF card eject button.
- To remove an SD card, use your finger to gently press it inward, then release.

NOTE

- Never turn off the power or disconnect a USB flash drive, CF card, or SD card while playback, recording, or editing is in progress. Doing so may damage the card.

Card Compatibility with Other Models in the AR Series

Using Cards Formatted on Earlier Model Units with the AR-3000SD

- Compact Flash cards used with AR-3000R/200R/200S/20PR/3000/200/20Ps can be used as is with the AR-3000SD.
- Files on PC cards used on AR-3000/200/2000/100 models can be used by copying the data to CompactFlash with the ARE-3000. Also, using the optional CFA-1 CF card adapter lets you copy data from a PC card to a CF card on the AR-3000.
- * Cards which have not been copied using ARE-3000 or an AR-3000 cannot be used.

Using Cards Formatted on the AR-3000SD with Earlier Models

- CF cards formatted on the AR-3000SD can be used as is with the AR-3000R/200R/200S/20PR/20P.
- Cards can be used as is with the AR-3000/200 by copying the data to PC card with the ARE-3000. Also, using the optional CFA-1 CF card adapter lets you copy data from a CF card to a PC card on the AR-3000.
- Cards cannot be used with the AR-2000/100.
- SD cards formatted on the AR-3000SD cannot be used on earlier models. The data they contain can be used by first using ARE-3000 to copy it to a CF card or PC card, but newly added functions on the AR-3000SD cannot be used by earlier models.

Important Note: About Setting Information Imported from a Card

When you insert a card into the slot, the unit imports setting information from the card.

Information such as system settings is imported from the system card. Whether the CF card or the SD card is the system card changes according to whether a card is present, the virtual slot setting, and the card priority setting.

CF	SD	System card			
		Virtual Slot: Off		Virtual Slot: On	
		CF: A SD: B	CF: B SD: A	CF: A/B SD: C/D	CF: C/D SD: A/B
Yes	Yes	CF: A	SD: A	CF: A	SD: A
Yes	No	CF: A	CF: B	CF: A	CF: C
No	Yes	SD: B	SD: A	SD: C	SD: A

The following setting information is imported from the system card

- Control input settings
- MIDI settings
- RS-232C settings
- System settings

The following setting information is imported from each card

- Recording settings
- Phrase settings
- Settings for card editing

Information Recorded on the Card

The AR-3000SD stores recorded audio and MIDI signals on the card.

Information such as system settings and phrase settings is also stored on the card. Only some system settings (such as the LCD contrast setting) are recorded in the unit itself.

This means you can switch all settings to the settings stored on a card simply by swapping cards.

About the Display

Viewing the Basic Screen

The explanations in this manual include illustrations that depict what should typically be shown by the display. Note, however, that your unit may incorporate a newer, enhanced version of the system (e.g., includes newer sounds), so what you actually see in the display may not always match what appears in the manual.

Screen During Audio Phrase Playback

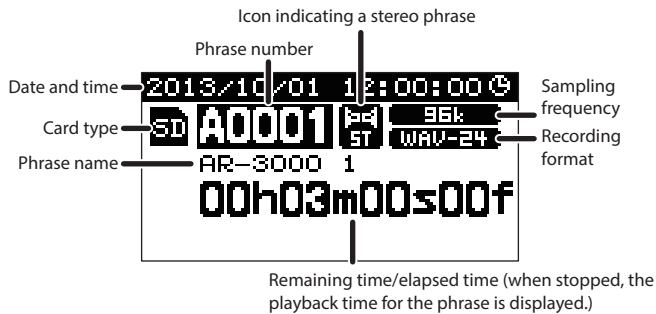

Song phrase

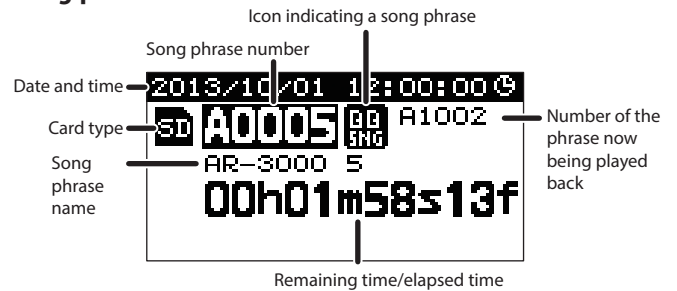

Phrase Parameters List Screen

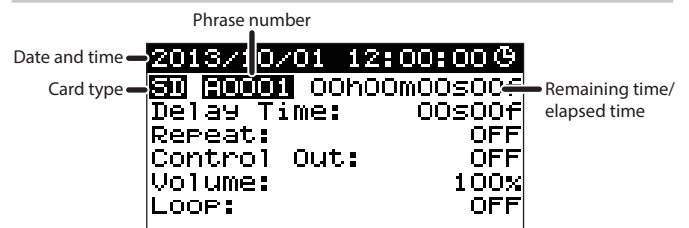

Screen During MIDI Phrase Playback

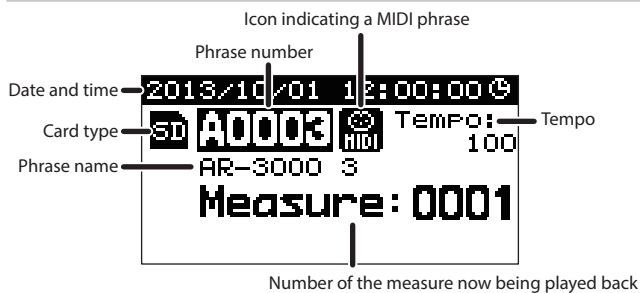

Screen During Pattern Phrase or Song Phrase Playback

Pattern phrase (Standby)

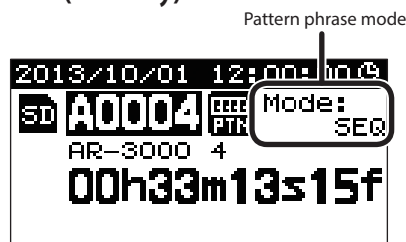

Pattern phrase (Playback)

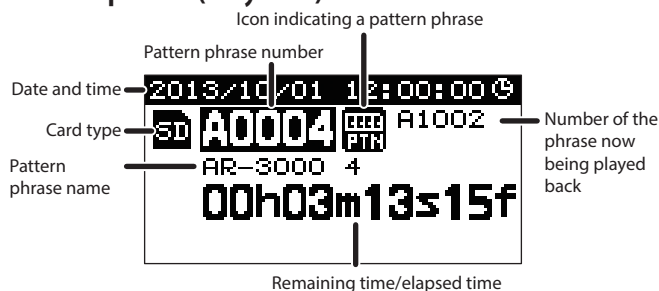

Display-Related Settings

NOTE

If you press the [MENU] button while making settings, a message asking you to confirm that you want to exit the setting process appears. Note that if you choose "YES," then press the [ENTER] button, you are returned to the usual screen, and all setting changes you've made up to that point will be discarded.

Adjusting the Contrast

You can adjust the contrast of the display. Adjust it to match your usage conditions.

Procedure for adjusting the display contrast

1. Press the [MENU] button.
The MENU indicator lights up.
2. Use the [SELECT] dial to choose "11.3 Contrast," then press the dial.
3. Turn the [SELECT] dial to set Contrast (-10 to +10), then press the dial.

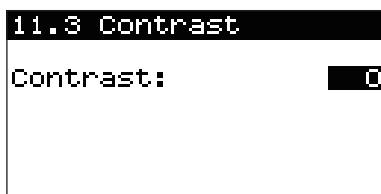

4. When the prompt appears on the screen, press the [ENTER] button to enable the settings.
To quit without making the settings, use the [SELECT] dial to choose "NO," then press the [ENTER] button.
When you're finished making the setting, the display returns to the setting item selection screen.
5. Press the [MENU] button.
This ends the setting process and returns you to the usual screen.

Making the Display Go Dark

You can make the display go dark automatically after a certain period of time has elapsed following the last operation in the phrase playback screen. You can set the time until the display goes dark (Sleep Time) to anything from 30 seconds to 59 minutes 59 seconds. When the unit is in continuous use for long periods, such as on systems that run 24 hours a day, this can help protect the display from deterioration. Set it to match your usage conditions.

Procedure for making the display go dark

1. Press the [MENU] button.
The MENU indicator lights up.
2. Use the [SELECT] dial to choose "9.5 Display Sleep," then press the dial.
3. Turn the [SELECT] dial to choose Display Sleep (ON), then press the dial.
4. Turn the [SELECT] dial to make the setting for Sleep Time (00 m 30 sec to 59 m 59 sec), then press the dial.

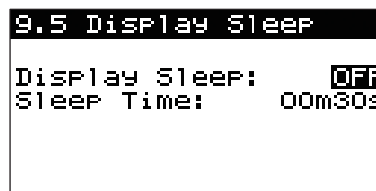

5. When the prompt appears on the screen, press the [ENTER] button to enable the settings.
To quit without making the settings, use the [SELECT] dial to choose "NO," then press the [ENTER] button.
When you're finished making the setting, the display returns to the setting item selection screen.
6. Press the [MENU] button.
This ends the setting process and returns you to the usual screen.

MEMO

While making the settings, you can go back to the previous entry position (highlighted) by using the [BACK] button.

Making the display appear again

When the display is dark, you can make it appear again quickly by pressing any of the six buttons.



Recording Audio

Recording Units (Phrases)

A single item of data recorded from the point where you start recording until the point where you stop recording is called a phrase. Audio data and MIDI data are both handled as phrases. Phrases are managed by phrase numbers.

Connecting Equipment

The AR-3000SD is equipped with a MIC jack (for microphone input) on the front panel and LINE IN jacks (for line input) on the rear panel. Make the connections to match the equipment you're using for recording. You can also record mixed microphone and line input.

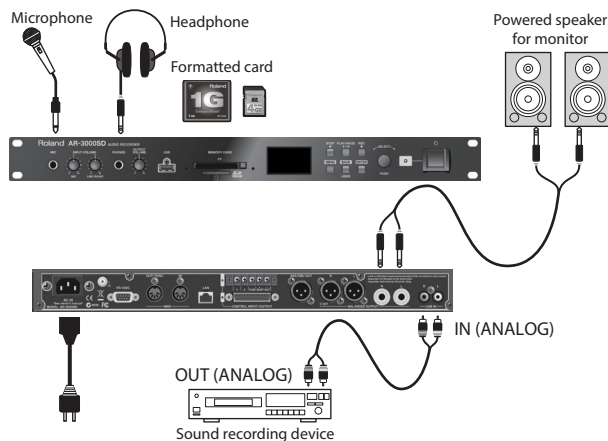

* To prevent malfunction and equipment failure, always turn down the volume, and turn off all the units before making any connections.

MEMO

Acoustic feedback could be produced depending on the location of microphones relative to speakers. This can be remedied by:

- Changing the orientation of the microphone(s).
- Relocating microphone(s) at a greater distance from speakers.
- Lowering volume levels.

Monitor output during recording and recording standby

Microphone input is output from the audio output jacks (BALANCED OUTPUT and PHONES) and B control connectors (MONO OUT) only during recording or recording standby, enabling you to monitor recording.

Line input can be output from the audio output jacks (BALANCED OUTPUT and PHONES) and B control connectors (MONO OUT) both during recording or recording standby and during playback.

- * Microphone input is not output to the audio output jacks (BALANCED OUTPUT and PHONES) or B control connectors (MONO OUT) during playback.
- * The sound quality of audio output from the audio output jacks (BALANCED OUTPUT and PHONES) and B control connectors (MONO OUT) while monitoring recording differs from the actual recorded audio. Be sure to play back the phrase after recording to confirm the quality of the recorded audio.

Procedure for Recording

NOTE

Cards in AR-2000 format cannot be used for recording.

Enabling Recording Standby

1. Make the correct connections, then turn on the [⏻] switch.
2. Insert a formatted card (p. 14) into one of the slots.
3. Turn the [SELECT] dial to choose the phrase number you want to record.
To switch between card slots CF and SD, press the [SELECT] dial.
4. Press the [REC] button.

The AR-3000SD enters standby for recording. During recording standby, the REC indicator flashes. If you try to re-record a phrase that's already been recorded, a prompt message appears. If you choose "YES" and press the [ENTER] button, the recorded data for the phrase is deleted and the unit goes into recording standby. If you choose "NO," the unit returns to the normal display.



- * Please be aware that data deleted here cannot be recovered, even if you cancel recording standby without recording anything.
- * When Card Protect (p. 26) is set to "ON," recorded phrases are protected and recording is not possible (writing, overwriting, deleting, and editing card data is prohibited).

MEMO

When you have created a new phrase by rerecording, the following phrase information remains in effect and is not deleted.

- 1.1 Play Volume (except MIDI Phrase)
- 1.2 Delay Time
- 1.4 Repeat Play
- 1.6 Fade (except MIDI Phrase)
- 1.7 Control Out
- 1.8 MIDI Tempo (only MIDI Phrase)
- 1.9 Phrase Name

Required Settings for Recording Audio Signals (Recording Settings)

In order to perform recording matched to usage conditions, including the connected equipment, recording source, sound quality, time, and playback system, you make recording settings.

- Recording settings are made in phrase units. You can mix phrases having different recording settings on a single card.
- The possible recording time of a card varies according to the recording settings. For a rough guide to maximum recording times with various settings, see the “Card-Specific Audio Recording Time Chart” (p. 26).
- You can use the system settings to select a sampling frequency of 32, 44.1, 48, or 96 kHz.
- When you don't change the recording settings, the recording settings for the most recent recording made on the specified card are used.
- If you don't need to change the recording settings in effect when the card was formatted, you can proceed to “Adjusting the recording level” (p. 21).

NOTE

Pressing the [SELECT] dial after finishing making recording settings does not apply the settings. Be sure to press the [ENTER] button.

Recording settings in effect when a card is formatted

Parameter	Value
REC-In (Selected recording connector)	LINE-IN
Recording format	WAV-16 (16 bit WAV)
Sampling frequency	44.1 kHz
REC Type	STEREO
Trig Level (Trigger recording setting)	OFF

Rec-in (selecting the recording connector)

Set the input connector to record from. Make the selection to match the connected device.

Parameter	Value
LINE-IN	LINE IN jacks
LINE+MIC-IN	LINE IN jacks and Mic jack
MIDI-IN	MIDI connector (In)

Procedure for selecting the recording connector

- Put the unit into recording standby.
- Turn the [SELECT] dial to choose “REC-In.”



- Press the [SELECT] dial to advance the input location (highlighted).



- Turn the [SELECT] dial to choose the REC-In (for audio recording, this is LINE-IN or LINE+MIC-IN), then press the ENTER button.

If you are continuing with the recording format setting, proceed to step 2 in the following section, “Procedure for setting the recording format.”

Procedure for setting the recording format

On the AR-3000SD, you can select from among eight types of recording formats.

Format	Explanation
WAV-24	24 bit WAV
WAV-16	16 bit WAV
MP3-320	MP3 320 kbps (Stereo)
MP3-192	MP3 192 kbps (Stereo)
MP3-128	MP3 128 kbps (Stereo)
MP3-160	MP3 160 kbps (Mono)
MP3-96	MP3 96 kbps (Mono)
MP3-64	MP3 64 kbps (Mono)

NOTE

Please note that when a sampling frequency of 96 kHz has been selected in the system settings, recording in MP3 format is not possible.

Important Note on Recording in MP3 format

Please note that settings for the following items cannot be made in phrase settings or phrase editing for phrases recorded in MP3 format.

- Phrase information**
 - Playback point
 - Loop play
- Phrase editing**
 - Pattern phrase
 - Song phrase

Important Note When Recording in WAV-24 format

Please note that settings for the following items cannot be made in phrase editing for phrases recorded in WAV-24 (24-bit WAV) format.

- Phrase editing**
 - Pattern phrase
 - Song phrase

Procedure for setting the recording format

- Put the unit into recording standby.
- Turn the [SELECT] dial to choose “Format,” then press the dial.



- Turn the [SELECT] dial to choose format, then press the [ENTER] button.

* Pressing the [PLAY/PAUSE] button instead of the [ENTER] button starts recording with the selected setting.

- The display of remaining time on the card available for recording changes according to the selected format.
- If you are continuing with the recording type setting, proceed to step 2 in the following section, “Procedure for Setting the Recording Type.”

Rec type (stereo or mono)

Select either stereo recording or mono recording.

Procedure for setting the recording type

1. Put the unit into recording standby.
2. Turn the [SELECT] dial to choose "REC Type," then press the dial.
3. Turn the [SELECT] dial to choose the REC Type (STEREO or MONO), then press the ENTER button.



- * Pressing the [PLAY/PAUSE] button instead of the [ENTER] button starts recording with the selected setting.
- The displayed remaining recording time available for recording on the card changes according to the selected recording setting.
- If you are continuing with the trigger recording settings, proceed to step 2 in the following section, "Trig level (trigger recording settings)."

Trig level (trigger recording settings)

A method for starting recording automatically when the audio input is higher than the trigger level (the volume level for starting recording) is called trigger recording. The following four types of trigger recording settings are available.

Value	Explanation
OFF	Trigger recording is not performed.
LOW	Recording starts when audio at a low volume level is input (-45 dB).
MID	Recording starts when audio at an intermediate volume level is input (-36 dB).
HIGH	Recording starts when audio at a high volume level is input (-27 dB).

- * When you are recording from microphone input with the trigger level set at "LOW," recording may be inadvertently started by ambient noise. If this happens, change the trigger level to MID or HIGH, or carry out recording in a quieter location.
- * If you quit recording without waiting for trigger recording to start, no phrase is created.

Procedure for the trigger recording setting

1. Put the unit into recording standby.
2. Turn the [SELECT] dial to choose "Trig Level," then press the dial.
3. Turn the [SELECT] dial to choose the Trig Level (OFF, LOW, MID, or HIGH), then press the [ENTER] button.

Adjusting the recording level

Input audio from the connected device and adjust the recording level. If the input volume level is too high, a symbol "OVER" like the one shown below appears on the display. If this happens, adjust the recording level by lowering the volume on the connected device or turning the [INPUT VOLUME] knobs on the unit so that the symbol does not appear.



Starting and Ending Recording

1. When the unit is in recording standby, press the [PLAY/PAUSE] button.

Recording starts. The REC and PLAY/PAUSE indicators light up while recording is in progress.

- When you have made the trigger recording setting, the unit waits for audio input higher than the trigger level (the volume level at which recording starts), then starts recording.



2. Press the [STOP] button.

Recording ends.

- * Recording cannot span two cards inserted in the slots. When the free space on one card is used up, recording ends automatically.

Starting and stopping recording with control input terminals

You can start and stop recording using a control input terminals.

For details, refer to "Reference Manual" (PDF).

Checking What You Recorded

After recording ends, you can play back the phrase by pressing the [PLAY/PAUSE] button.

You can verify the phrase's sampling frequency, recording format, recording type, and recording time by viewing the display.



Playback Using the Panel on the Unit (Manual Playback)



1. Insert a card containing recorded data into a slot.
2. Turn the [SELECT] dial to choose the phrase number to play.

To switch between card slots CF and SD, press the SELECT dial.

3. Press the [PLAY/PAUSE] button.

The phrase is played back.

During playback of the phrase, the PLAY indicator lights up.

- During playback of the phrase, pressing the [PLAY/PAUSE] button pauses audio playback. While playback is paused, the PLAY/PAUSE indicator flash. To resume playback, press the [PLAY/PAUSE] button.
- Pressing the [STOP] button ends playback.
- During playback, you can choose the next song to play (without stopping the phrase being played) by turning the [SELECT] dial.

NOTE

- Note that playback cannot be paused in the following cases:
 - Phrase recorded in MP3 or RDAC MODE2 format
 - MIDI phrase
 - Pattern phrase
 - Song phrase
 - Dual Mono mode (ON)
- Playback cannot be paused during crossfade, repeat play, or interval play.

Playback location search

While paused, you can move the current phrase location forward or backward by turning the [SELECT] dial. To switch the unit of change, press the SELECT dial. (The units cycle through the sequence of frame → second → minute → hour → frame.)

Pressing the [PLAY/PAUSE] button again starts playback at the specified location.

Time shown on the display

During playback or while playback is paused, you switch the time shown on the display between "Remaining Time (REMAIN)" and "Elapsed Time" by pressing the [ENTER] button.

Elapsed time



Remaining time



Keeping the Output Volume Unchanged (Output Volume Thru)

This deactivates the [OUTPUT VOLUME] knob and keeps the output volume level unchanged to prevent accidental operation.

* The OUTPUT VOLUME knob can still be used to adjust the headphones volume and MONO OUT (Control Input/Output Terminals) even when Volume Thru is set to "ON."

Value	Explanation
OFF	The Output Volume control is effective.
ON	The Output Volume control is deactivated.

When Volume Thru is set to "On," the volume is fixed at the level obtained when the control is centered (that is, when positioned at 5).

Procedure for Making the Output Volume Thru Setting

1. Press the [MENU] button.
The MENU indicator lights up.
2. Use the [SELECT] dial to choose "9.3 Output Vol. Thru," then press the dial.
3. Turn the [SELECT] dial to choose Volume Thru (OFF or ON), then press the dial.
4. When the prompt appears on the screen, press the [ENTER] button to enable the settings.
To quit without making the settings, use the [SELECT] dial to choose "NO," then press the [ENTER] button.
When you're finished making the setting, the display returns to the setting item selection screen.
5. Press the [MENU] button.
This ends the setting process and returns you to the usual screen.

Troubleshooting

About recording	
Can't record a connected device	Has the selection of the recording connector (LINE-IN, LINE+MIC-IN, or MIDI-IN) been made correctly? Make sure the device connected to the connector matches the selected recording connector.
Recording does not start	Is the trigger recording setting set to LOW, MID, or HIGH? In trigger recording, recording starts automatically when the audio input is of a higher level than the trigger level (lever for starting recording). If you are not conducting trigger recording, set it to "OFF."
About playback	
Phrases are not played back correctly	Has the card been formatted on a computer? Be sure to format cards on an AR series device.
Phrases are not played back (PLAY/PAUSE indicator flashing rapidly)	Is the MTC "Sync Source" set to "MTC?" When not synchronizing playback with MTC and using the AR-3000SD as a slave, set "Sync Source" on the AR-3000SD to "INTERNAL."
Pattern phrases and song phrases are not played back as intended	When creating a pattern phrase or song phrase, you can choose actual phrases with constituents from both CF card and SD card. At the time of playback, however, if the card containing the constituent phrases is not inserted, playback will not occur in the normal fashion. If a constituent phrase is not present, the unit seeks and plays back the next phrase. Make sure the phrases assigned during creation exist on the cards.
The start of phrase playback is delayed when playback is controlled from an external device	Has the "Delay Time" been set for the phrase? Try playing back the phrase by pressing the AR-3000SD's [PLAY/PAUSE] button (manual operation). If the start of playback is delayed, check the AR-3000SD to confirm whether or not the delay time has been set. If the playback is correct when you press the AR-3000SD's [PLAY/PAUSE] button, check the control signals being sent from the external control device, connections and so on once more.
Control Input Playback (Direct/Program/Binary) does not work as intended	Select the correct type of control input (Direct, Program, or Binary). You cannot achieve control input playback merely by connecting a device to the port. Be sure to set the control input mode and match the method used for connecting to the connectors.
Phrases in Direct Playback cannot be selected as intended	Phrases are assigned to Ports 1 to 16 by means of settings made on the AR-3000SD. When a card is formatted, the assignments are Port No. 1-phrase A0001, Port No. 2-phrase A0002,..., Port No. 16-phrase A0016.
Phrases in Direct Playback do not stop playing	Check the phrase settings and make sure that "Repeat Play" is not set to "ON."
In Program Playback, phrases cannot be selected as intended.	The assignments of phrases in the Program Playback sequence are made with settings on the unit. When a card is formatted, the assignments are No. 1-phrase A0001, No. 2-phrase A0002,..., No. 100-phrase A0100.
Dual Mono playback does not work as intended.	In the system settings, is "Dual Mono Mode" set to "OFF (STEREO 1 ch)?" When you are using Dual Mono mode, be sure to set this to "ON (MONO 2 ch)." Also, Dual Mono mode playback is subject to a wide variety of conditions. For detailed information on conditions, refer to the description of the Dual Mono mode in the "Reference Manual" (PDF).
The RS-232C port connection does not work as intended	In the RS-232C settings, do you have the correct "Baud Rate" selected? When you are using the RS-232C port, select a value that matches that of the equipment you are using. In addition, check the device connections for the RS-232C connector. Have you been using the AR-2000 up to now? The RS-232C settings on the AR-3000SD include an "AR-2000 compatibility mode" setting. For more details, refer to the "Reference Manual" (PDF).

About playback and recording of MIDI phrases	
MIDI phrases cannot be recorded correctly	Some MIDI sequencers output MIDI sound generator setup messages (tone settings for each part, volume information, effects data, and so on) when a song is selected, and this may prevent MIDI messages from being recorded correctly when recording with the AR-3000SD begins. In such instances, start recording with the AR-3000SD first, then select and play back the song from the MIDI sequencer.
MIDI data cannot be recorded	Is "MIDI-IN" selected as the recording connector? When you're recording MIDI data, choose "MIDI-IN" as the recording connector.
The displayed tempo for a MIDI phrase remains at 120	The initial tempo of the AR-3000SD is 120, so even if you record MIDI data having variable tempo to a MIDI phrase, tempo information is not recorded. This means that the displayed tempo does not change during playback of MIDI phrases, but this is not a defect.
MIDI phrases are not played back	Is "OUT" selected for MIDI output (MIDI OUT or THRU)? OUT: This sends out MIDI information from the AR-3000SD. Select this when you want to play back MIDI phrases or send Exclusive (SysEx) messages. THRU: This takes MIDI information from MIDI IN and sends it out unchanged. MIDI information from the AR-3000SD is not sent. Is the MIDI Receive channel set to "OFF?"
About MIDI control playback	
Phrases cannot be played back as intended in MIDI Control Playback	The assignments of phrases to the note numbers for Program Change 1 are made with settings on the unit. When a card is formatted, the assignments are Program Change 1, C-1: A0001 through G9: A0128. Also, you can assign 128 phrases of your choosing to Program Change 1, but please be aware that the phrase assignments to other program changes cannot be changed. For details, refer to "Reference Manual" (PDF).
Operation cannot be synchronized	Is the MIDI output (MIDI OUT or THRU) selected correctly? OUT: This sends out MIDI information from the AR-3000SD. Select this when you want to play back MIDI phrases or send Exclusive (SysEx) messages. THRU: This takes MIDI information from MIDI IN and sends it out unchanged. MIDI information from the AR-3000SD is not sent. Are the MTC "Sync Source" and "Sync Out" set correctly? Make the correct settings to match the circumstances, according to whether the AR-3000SD is the master or the slave. If using MTC, are both devices set to the same MTC type? Check the AR-3000SD to confirm that the MIDI device ID settings are correct.

Troubleshooting

Other Effects	
No sound	<ul style="list-style-type: none"> • Reconfirm that the power to the AR-3000SD or connected device is on. • Reconfirm that the volume control on the AR-3000SD or connected device is turned up. • Reconfirm that there are no shorts in any connector cables.
The volume level of the instrument connected to LINE IN jacks is too low.	<p>Could you be using a connection cable that contains a resistor? Use a connection cable that does not contain a resistor.</p>
Sound input to the Mic jack is not output from the audio output jacks	<p>Sound input to the Mic jack is output from the audio output jacks only during recording or recording standby (REC-In: LINE+MIC-IN). Please be aware that output at times other than recording or recording standby (REC-In: LINE+MIC-IN) is not possible.</p>
Unable to connect to a LAN device	<ul style="list-style-type: none"> • Make sure the power to the AR-3000SD and the LAN device is turned on. • Make sure the AR-3000SD is connected to the correct port of the LAN device. • Check whether the setting for DHCP has been made on the AR-3000SD. • If the AR-3000SD is being used with DHCP set to OFF, make sure the settings for IP ADDRESS and SUBNET (subnet mask) are correct. • Check whether the setting for DHCP has been made on the LAN device.
The power turns off by itself	<p>Depending on the setting for Auto Off, the power is turned off automatically after no operation has been performed for a certain time.</p>
The internal clock was reset	<p>The settings of the internal clock return to their default values if the power to the unit remains turned off for several days. When the power is turned on while the unit is in this default state, the message "Set the clock" is displayed. If this message appears, set the time and date again.</p>

Error Messages

If there has been a mistake in operation, or if the AR-3000SD is unable to continue processing as you directed, an error message will appear in the display. Note the message that appears, and take the appropriate action.

Display	Situation	Action
Regarding Cards		
No card found. Insert a card.	No card is inserted into either of the card slots.	Insert a card.
Incorrect format. Format card.	The memory card is not formatted for use with the AR-3000SD.	Format the memory card.
Damaged card. Format card.	It is possible that the data in the memory card or the memory card itself has been damaged.	Format the memory card. If formatting is not possible, or if the same message appears after the card has been formatted, it may be that the memory card is malfunctioning. Use a different memory card.
Card full. Delete phrases.	Data cannot be stored on the card because there is no free space.	Increase the amount of free space on the card, such as by deleting unneeded phrases.
Unsupported card. Change cards.	This memory card cannot be used by the AR-3000SD.	Use an AR-3000SD compatible memory card.
Protected card. Write Failure.	Card protect is set to ON, so data cannot be written to the card.	Set card protect to OFF.
Write-protected. Cannot write to card.	The card's write-protect switch is on.	Switch off the write-protect switch on the SD/SDHC memory card.
Cannot change to AR-2000 card.	Because the card is in AR-2000 format, setting changes and the like cannot be written to the card.	Convert the card to AR-3000 format, or use another card that is in AR-3000 format.
Playback Related		
Cannot play. Check phrase.	Either the phrase data is damaged, or the AR-3000SD is not able to handle the phrase.	Check the phrase for which the message was displayed.
No corresponding phrase.	There is no phrase corresponding to the specified phrase.	Select a saved phrase or record a new phrase.
Recording Related		
Card access error. Change conditions.	Data was not written to or read from the card in time.	Change the sampling frequency, recording format, or other recording conditions to reduce the amount of data.
Editing		
Cannot set for selected phrase.	A setting item does not correspond to the selected phrase.	Reselect a phrase for which the setting can be made, or record a new phrase.
MIDI Related		
MIDI buffer overflow.	More MIDI data was received in a short time than the AR-3000SD was able to process.	Change the way in which MIDI data is being transmitted.
MIDI Out at THRU. Nothing Sent.	Because MIDI output is set to THRU, MIDI data cannot be sent.	Set MIDI output to OUT.
No active sense. Recording stopped.	MIDI Active Sense was interrupted.	Check the status of the transmitter and the MIDI cable connections.
MIDI checksum error.	Checksum error found in received MIDI data.	Check the transmission status and the MIDI data.
Others		
LAN buffer overflow.	A large amount of data was received in a short time, and LAN inbound processing could not be performed.	Change the method of data transmission.
Clock is initialized.	This appears when the clock backup battery has been depleted or the time setting has been initialized.	Use the clock settings to set the current date and time.

Card-Specific Audio Recording Time Chart

The following table shows recording times available for cards formatted for the AR-3000SD.

- * These times are for when 1 phrase is recorded continuously, and are provided for your reference when recording. The recording time will depend on the combination of the grade settings of each phrase recorded in each memory card.
- * For the most up-to-date information, see the Roland website (<http://www.roland.com/support/>).

CF-512

Format	Bit depth/Bit rate	Channels	Sampling frequency			
			96 kHz	48 kHz	44.1 kHz	32 kHz
WAV	24-bit	Stereo	14 min	28 min	30 min	42 min
WAV	24-bit	Mono	28 min	56 min	1 hour 01 min	1 hour 24 min
WAV	16-bit	Stereo	21 min	42 min	46 min	1 hour 03 min
WAV	16-bit	Mono	42 min	1 hour 24 min	1 hour 32 min	2 hour 07 min
MP3	320 kbps	Stereo	—	3 hour 23 min		
MP3	160 kbps	Mono		6 hour 46 min		
MP3	192 kbps	Stereo		5 hour 39 min		
MP3	96 kbps	Mono		11 hour 18 min		
MP3	128 kbps	Stereo		8 hour 28 min		
MP3	64 kbps	Mono		16 hour 57 min		

CF-01G

Format	Bit depth/Bit rate	Channels	Sampling frequency			
			96 kHz	48 kHz	44.1 kHz	32 kHz
WAV	24-bit	Stereo	28 min	57 min	1 hour 02 min	1 hour 25 min
WAV	24-bit	Mono	57 min	1 hour 54 min	2 hour 04 min	2 hour 51 min
WAV	16-bit	Stereo	42 min	1 hour 25 min	1 hour 33 min	2 hour 08 min
WAV	16-bit	Mono	1 hour 25 min	2 hour 51 min	3 hour 06 min	4 hour 16 min
MP3	320 kbps	Stereo	—	6 hour 50 min		
MP3	160 kbps	Mono		13 hour 41 min		
MP3	192 kbps	Stereo		11 hour 24 min		
MP3	96 kbps	Mono		22 hour 49 min		
MP3	128 kbps	Stereo		17 hour 07 min		
MP3	64 kbps	Mono		34 hour 14 min		

SD-04G

Format	Bit depth/Bit rate	Channels	Sampling frequency			
			96 kHz	48 kHz	44.1 kHz	32 kHz
WAV	24-bit	Stereo	1 hour 54 min	3 hour 48 min	4 hour 09 min	5 hour 43 min
WAV	24-bit	Mono	3 hour 48 min	7 hour 37 min	8 hour 18 min	11 hour 26 min
WAV	16-bit	Stereo	2 hour 51 min	5 hour 43 min	6 hour 13 min	8 hour 34 min
WAV	16-bit	Mono	5 hour 43 min	11 hour 26 min	12 hour 27 min	17 hour 09 min
MP3	320 kbps	Stereo	—	27 hour 27 min		
MP3	160 kbps	Mono		54 hour 55 min		
MP3	192 kbps	Stereo		45 hour 45 min		
MP3	96 kbps	Mono		91 hour 31 min		
MP3	128 kbps	Stereo		68 hour 38 min		
MP3	64 kbps	Mono		137 hour 17 min		

* Some memory card types or memory cards from some manufacturers may not record or play back properly on the unit.

- * The memory card write protect feature (LOCK)
The contents of the memory card can be protected by write protecting it. To write protect a card, slide the write protect switch on the side of the memory card to the "LOCK" position. Unlock write protect to delete data on the card.

Write protect switch

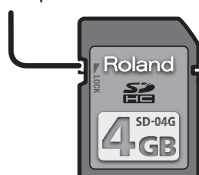

* All memory cards eventually wear out. We recommend that you consider the memory card not as a permanent storage site, but as a place to store data temporarily. We also recommend that you back up important data onto the another media that is supported by your unit.

Terminals

Specifications of the Control Input/Output Terminals

Control Input/Output Terminal A

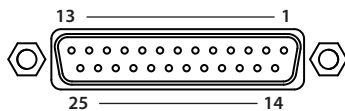
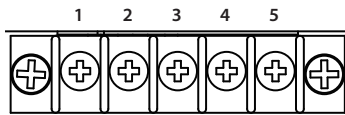

Control Input/Output Terminal B

Control Input/Output Terminal A

Control port	Direct playback	Explanation
1	No. 1	Control input
2	No. 2	
3	COM (GND)	
4	BUSY OUT (+)	Control output
5	BUSY OUT (-)	

Control Input/Output Terminal B

Control port	Direct playback	Binary playback	Control-port recording	Program playback	Explanation
1	No. 1	Phrase bit 0		INC	Control input
2	No. 2	Phrase bit 1			
3	No. 3	Phrase bit 2		DEC	
4	No. 4	Phrase bit 3			
5	No. 5	Phrase bit 4		EXCHANGE	
6	No. 6	Phrase bit 5			
7	No. 7	Phrase bit 6			
8	No. 8	Phrase bit 7			
9	No. 9	START	START	START	Control output
10	STOP	STOP	REC	STOP	
11	COM (GND)				
12	COM (GND)				
13	BUSY OUT (+)				Control output
14	No. 10	Card bit 0			Control input
15	CONT OUT (+)				Control output
16	No. 11	Card bit 1			Control input
17	BUSY OUT (-)				Control output
18	CONT OUT (-)				
19	MONO OUT (SIG)				Audio output
20	MONO OUT (GND)				
21	No. 12	Phrase bit 8			Control input
22	No. 13	Phrase bit 9			
23	No. 14				
24	No. 15				
25	No. 16				

Control input

Trigger Signal Format	On, Off (Open, Close), Pulse width: 20 msec or more
Contact capacity	DC 24 V, 0.1 A or more
Input	Photocoupler

- * During binary playback, complete input specifying binary signals within 50 ms.
- * The common (COM) connectors of control terminal A and control terminal B are connected inside, so you can achieve operation by making the connection to either one. In cases such as when you are connecting the control connectors of a number of AR units with a single make-contact point, connect one COM connector on each AR unit to each other. However, do not intermix this unit with other AR series devices. Doing so may result in unstable operation.
- * The control I/O connector cannot be used to switch the power to the AR unit on or off.

Control output

Signal system	No-voltage make-contact
Contact capacity	DC 24 V, 2.0 A
Connectors used with control output:	Busy Out: BUSY OUT Control Out: CONT OUT, make-contact time: 1 second

Audio output ports (MONO OUT)

MONO OUT is an audio output (mono, unbalanced) ports.

Rated output level	+4 dBu
Output impedance	300 Ω
Recommended Load Impedance	10 kΩ or greater

- * The output levels may change for stereo and mono audio phrases.

NOTE

When making connections to the ports, be careful not to lose the removed screws. Place the screws out of the reach of small children. If a screw is accidentally swallowed, immediately consult a physician.

RS-232C Connector Specifications

Transmission method	Start-Stop synchronous system (Asynchronous) Duplex data transmission
Baud rate	4800, 9600, 14400, 19200, 31250, 38400, 57600, 115200 bps
Parity	none
Data length	8 bit
Stop bit length	1 bit
Code set	ASCII

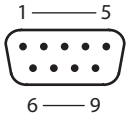
Pin No.	Signal Name	Pin Connection
1	NC	
2	RXD	
3	TXD	
4	DTR	
5	GND	
6	DSR	
7	RTS	
8	CTS	
9	NC	

AR-3000SD	Computer
1 : NC	1 :
2 : RXD	2 : RXD
3 : TXD	3 : TXD
4 : DTR	4 :
5 : GND	5 : GND
6 : DSR	6 :
7 : RTS	7 :
8 : CTS	8 :
9 : NC	9 :

* These are already connected in inside of the AR-3000SD (4-6 and 7-8).

* At least three lines (RXD, TXD and GND) should be connected as shown in a figure.

* In addition to the owner's manual, "Command Reference Manual" (PDF) is available as a reference material that cover RS-232C connector control. The PDF file can be downloaded free of charge from the following URL.

* The "Command Reference Manual" (PDF) cover the following topics:

- Setup
- Overviews, detailed descriptions, and lists of commands
- About the Error code
- Examples of usage algorithms

Roland website

<http://www.roland.com/support/>

Specification

Roland AR-3000SD: Audio Recorder

Recorder Part

Data Type	
Recording	
File format	WAV
Sampling frequency	32 k, 44.1 k, 48 k, 96 kHz
Bit depth	16, 24 bits
Channels	mono, stereo
File format	MP3 (MPEG-1 audio layer 3)
Sampling frequency	32 k, 44.1 k, 48 kHz
Bit rate	128 k, 192 k, 320 kbps
Channels	stereo
File format	MP3 (MPEG-1 audio layer 3)
Sampling frequency	32 k, 44.1 k, 48 kHz
Bit rate	64 k, 96 k, 160 kbps
Channels	mono
File format	Standard MIDI Files (Format 0)
Playback	
File format	WAV
Sampling frequency	8 k, 16 k, 22.05 k, 32 k, 44.1 k, 48 k, 96 kHz
Bit depth	16, 24 bits
Channels	mono, stereo
File format	MP3 (MPEG-1 audio layer 3)
Sampling frequency	32 k, 44.1 k, 48 kHz
Bit rate	32 k–320 kbps or VBR (Variable Bit Rate)
Channels	mono, stereo
File format	RDAC (Roland Digital Audio Coding)
RDAC Grade (Sampling frequency)	8 k, 16 k, 22.05 k, 32 k, 44.1 k, 48 kHz
RDAC Mode	MODE1, MODE2, MODE3, LINEAR (16-bit linear), H-LINEAR (24-bit linear)
RDAC Type (Channels)	mono, stereo
File format	Standard MIDI Files (Format 0)
Number of phrases	
Maximum 4,000 phrases (using 1000 x 2 phrases format CF card and SD/SDHC memory card)	
Recording Media	
CF Card	up to 32 GB
SDHC Memory Card	4–32 GB
SD Memory Card	up to 2 GB
Maximum Recording Time	
171 hours (using 1GB CF card and SD-04G 4GB SDHC memory card, MP3, 64 kbps, mono)	
* This recording time is approximate. Actual results may vary somewhat.	
* In case that there are plural files, the sum of recording time would be shorter than above.	

Input/Output

MIC jack: 1/4-inch TRS phone type (balanced, unbalanced connection is possible)	
Input Sense	-43 dBu (unbalanced)
Nominal Input Level	-38 dBu (INPUT VOLUME - MIC at 8 position, unbalanced)
Maximum Input Level	-5 dBu (unbalanced)
Input Impedance	2 kΩ
Recommended Source Impedance	1 kΩ or less
LINE IN jacks (MONO/L, R): RCA phono type (unbalanced)	
Input Sense	-15 dBu
Nominal Input Level	0 dBu (INPUT VOLUME - LINE at 5 position)
Maximum Input Level	+20 dBu
Input Impedance	20 kΩ
Recommended Source Impedance	2 kΩ or less
BALANCED OUTPUT jacks (L, R): XLR type (balanced), 1/4-inch TRS phone type (balanced)	
Nominal Output Level	+10 dBu (OUTPUT VOLUME at 5 position)
Maximum Output Level	+22 dBu
Output Impedance	600 Ω
Recommended Load Impedance	10 kΩ or greater
MONO OUT (CONTROL INPUT/OUTPUT B connector): DB-25 type (unbalanced)	
Nominal Output Level	+4 dBu
Maximum Output Level	+16 dBu
Output Impedance	300 Ω
Recommended Load Impedance	10 kΩ or greater
PHONES jack: Stereo 1/4-inch phone type	
Maximum Output Level	90 mW + 90 mW (1 kHz, 40 ohms load, typ.)
Output Impedance	100 Ω
Recommended Load Impedance	30 Ω or greater
AES/EBU OUT jack: XLR type	
Conforms to IEC 60958-4	

Characteristics

Residual Noise Level	
BALANCED OUTPUT	-80 dBu or less (Input short, INPUT VOLUME - MIC at 0 position, INPUT VOLUME - LINE at 5 position, OUTPUT VOLUME at 5 position, IHF-A, typ.)

Specification

Other Terminals

CONTROL INPUT/ OUTPUT A connector	5 pin terminal block with M3 screws
CONTROL INPUT/ OUTPUT B connector	DB-25 type
LAN port	RJ45 type Standard: IEEE802.3u (100BASE-TX) Transmission Speed: 100 Mbps
MIDI (OUT/THRU, IN) connector	
RS-232C connector	DB-9 type Transmission method: Start-Stop synchronous system (Asynchronous) Duplex Baud rate: 4800, 9600, 14400, 19200, 31250, 38400, 57600, 115200 bps Parity: none Data length: 8 bits Stop bit length: 1 bit Code set: ASCII
USB port	USB Type A USB 1.1, USB Mass Storage Class, USB HID Class * USB HDD cannot be used.

Other

Display	Graphic LCD 128 x 64 dots
Programmable Timer	Number of programs: 50 events x 14 days Schedule: Weekly schedule and yearly schedule Clock adjustment: NTP client Clock backup time: approx. 5 days
Power Supply	AC 117 V, AC 115 V, AC 230 V, AC 240 V, AC 220 V
Power Consumption	18 W
Dimensions	482 (W) x 310 (D) x 44 (H) mm 19 (W) x 12-1/4 (D) x 1-3/4 (H) inches (EIA-1U rack mountable)
Weight	3.3 kg 7 lbs 5 oz
Operating Free-air Temperature Range	0–40 degrees Celsius 32–104 degrees Fahrenheit
Accessories	Owner's Manual Power cord Rubber Foot x 4 Card Protector x 1 (with 2 Screws)
Options (sold separately)	SD/SDHC memory card: SD-04G

0 dBu = 0.775 Vrms

* In the interest of product improvement, the specifications and/or appearance of this unit are subject to change without prior notice.

Dimensions

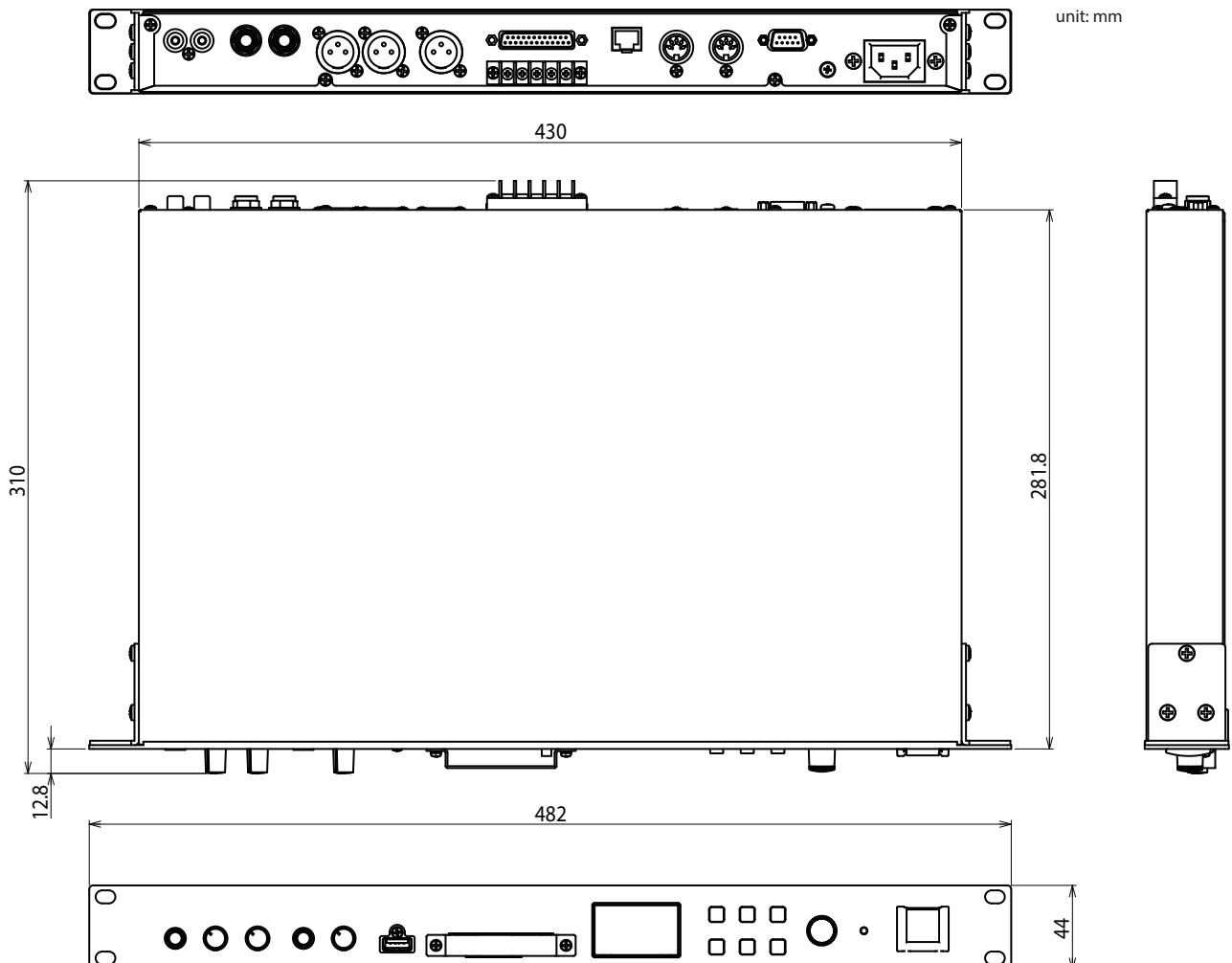

Index

[⓪] switch..... 8

A

AC IN jack..... 9
AES/EBU OUT jack..... 9
Auto Off..... 11

B

[BACK] (USER) button..... 8
BALANCED OUTPUT jack..... 9
Binary playback..... 13

C

Card
 Card compatibility..... 15
 Format..... 14
 Information recorded on the card..... 16
 Setting information imported from a card..... 16
Card protector..... 10
Card-Specific audio recording time chart... 26
CF card..... 15
CF card eject button..... 8
CF card slot..... 8
Connection..... 12
Connection methods..... 13
CONTROL INPUT/OUTPUT terminals..... 9, 12
 Specifications of the control Input/Output terminals..... 27

D

Date..... 11
Dimensions..... 30
Direct playback..... 13
Display..... 17
 Adjusting the contrast..... 18
 Making the display appear again..... 18
 Making the display go dark..... 18
 Time shown on the display..... 22
Dual mono mode..... 13

E

[ENTER] button..... 8
Error message..... 25

F

Front panel..... 8

G

Ground terminal..... 9

I

Indicator..... 8
INPUT VOLUME
 [LINE IN] knob..... 8
 [MIC] knob..... 8
Installation..... 10

L

LAN port..... 9, 13
LINE IN jack..... 9

M

[MENU] button..... 8
MENU indicator..... 8
MIC jack..... 8
MIDI connector..... 9, 12
Monitor output..... 19
Mono..... 21

O

[OUTPUT VOLUME] knob..... 8

P

PHONES jack..... 8
Phrase combination..... 13
Phrases..... 19
Playback location search..... 22
[PLAY/PAUSE] button..... 8
PLAY/PAUSE indicator..... 8
Power indicator..... 8
Programmable Timer..... 13
Program playback..... 13

R

Rack mounting..... 10
Rear panel..... 9
[REC] button..... 8
REC indicator..... 8
Recording..... 19
 Recording format..... 20
 Recording level..... 21
 Recording Settings..... 20
 Rec type..... 21
RS-232C connector..... 9, 13
 Connector specifications..... 28
Rubber foot..... 10

S

SD card..... 15
SD/SDHC memory card slot..... 8
[SELECT] dial..... 8
Stereo..... 21
[STOP] button..... 8
System card..... 16
System examples..... 12

T

Time..... 11
Trigger recording..... 21
Turning the unit on and off..... 11

U

Usage..... 12
Usage tips..... 13
USB flash drive..... 8, 15
USB port..... 8

V

Volume thru..... 22

MEMO

MEMO

For EU Countries



- UK** This symbol indicates that in EU countries, this product must be collected separately from household waste, as defined in each region. Products bearing this symbol must not be discarded together with household waste.
- DE** Dieses Symbol bedeutet, dass dieses Produkt in EU-Ländern getrennt vom Hausmüll gesammelt werden muss gemäß den regionalen Bestimmungen. Mit diesem Symbol gekennzeichnete Produkte dürfen nicht zusammen mit dem Hausmüll entsorgt werden.
- FR** Ce symbole indique que dans les pays de l'Union européenne, ce produit doit être collecté séparément des ordures ménagères selon les directives en vigueur dans chacun de ces pays. Les produits portant ce symbole ne doivent pas être mis au rebut avec les ordures ménagères.
- IT** Questo simbolo indica che nei paesi della Comunità europea questo prodotto deve essere smaltito separatamente dai normali rifiuti domestici, secondo la legislazione in vigore in ciascun paese. I prodotti che riportano questo simbolo non devono essere smaltiti insieme ai rifiuti domestici. Ai sensi dell'art. 13 del D.Lgs. 25 luglio 2005 n. 151.
- ES** Este símbolo indica que en los países de la Unión Europea este producto debe recogerse aparte de los residuos domésticos, tal como está regulado en cada zona. Los productos con este símbolo no se deben depositar con los residuos domésticos.
- PT** Este símbolo indica que nos países da UE, a recolha deste produto deverá ser feita separadamente do lixo doméstico, de acordo com os regulamentos de cada região. Os produtos que apresentem este símbolo não deverão ser eliminados juntamente com o lixo doméstico.
- NL** Dit symbool geeft aan dat in landen van de EU dit product gescheiden van huishoudelijk afval moet worden aangeboden, zoals bepaald per gemeente of regio. Producten die van dit symbool zijn voorzien, mogen niet samen met huishoudelijk afval worden verwijderd.
- DK** Dette symbol angiver, at i EU-lande skal dette produkt opsamles adskilt fra husholdningsaffald, som defineret i hver enkelt region. Produkter med dette symbol må ikke smides ud sammen med husholdningsaffald.
- NO** Dette symbolet indikerer at produktet må behandles som spesialavfall i EU-land, iht. til retningslinjer for den enkelte regionen, og ikke kastes sammen med vanlig husholdningsavfall. Produkter som er merket med dette symbolet, må ikke kastes sammen med vanlig husholdningsavfall.

- SE** Symbolen anger att i EU-länder måste den här produkten kasseras separat från hushållsavfall, i enlighet med varje regions bestämmelser. Produkter med den här symbolen får inte kasseras tillsammans med hushållsavfall.
- FI** Tämä merkintä ilmaisee, että tuote on EU-maissa kerättävä erillään kotitalousjätteistä kunkin alueen voimassa olevien määräysten mukaisesti. Tällä merkinnällä varustettuja tuotteita ei saa hävittää kotitalousjätteiden mukana.
- HU** Ez a szimbólum azt jelenti, hogy az Európai Unióban ezt a terméket a háztartási hulladéktól elkülönítve, az adott régióban érvényes szabályozás szerint kell gyűjteni. Az ezzel a szimbólummal ellátott termékeket nem szabad a háztartási hulladék közé dobni.
- PL** Symbol oznacza, że zgodnie z regulacjami w odpowiednim regionie, w krajach UE produktu nie należy wyrzucać z odpadami domowymi. Produktów opatrzonych tym symbolem nie można utylizować razem z odpadami domowymi.
- CZ** Tento symbol udává, že v zemích EU musí být tento výrobek sbírán odděleně od domácího odpadu, jak je určeno pro každý region. Výrobky nesoucí tento symbol se nesmí vyhazovat spolu s domácím odpadem.
- SK** Tento symbol vyjadruje, že v krajinách EÚ sa musí zber tohto produktu vykonávať oddelene od domového odpadu, podľa nariadení platných v konkrétnej krajine. Produkty s týmto symbolom sa nesmú vyhazovať spolu s domovým odpadom.
- EE** See sümbol näitab, et EL-i maades tuleb see toode olemprügist eraldi koguda, nii nagu on igas piirkonnas määratletud. Selle sümboliga märgitud tooteid ei tohi ära visata koos olmeprügiga.
- LT** Šis simbolis rodo, kad ES šalyse šis produktas turi būti surenkamas atskirai nuo buitinių atliekų, kaip nustatyta kiekviename regione. Šiuo simboliu paženklinėti produktai neturi būti išmetami kartu su buitiniams atliekomis.
- LV** Šis simbols norāda, ka ES valstīs šo produktu jāievāc atsevišķi no mājsaimniecības atkritumiem, kā noteikts katrā reģionā. Produktus ar šo simbolu nedrīkst izmest kopā ar mājsaimniecības atkritumiem.
- SI** Ta simbol označuje, da je treba proizvod v državah EU zbirati ločeno od gospodinjiskih odpadkov, tako kot je določeno v vsaki regiji. Proizvoda s tem znakom ni dovoljeno odlagati skupaj z gospodinjiskimi odpadki.
- GR** Το σύμβολο αυτό υποδηλώνει ότι στις χώρες της Ε.Ε. το συγκεκριμένο προϊόν πρέπει να συλλέγεται χωριστά από τα υπόλοιπα οικιακά απορρίμματα, σύμφωνα με όσα προβλέπονται σε κάθε περιοχή. Τα προϊόντα που φέρουν το συγκεκριμένο σύμβολο δεν πρέπει να απορρίπτονται μαζί με τα οικιακά απορρίμματα.

For China

有关产品中所含有害物质的说明

本资料就本公司产品中所含的特定有害物质及其安全性予以说明。

本资料适用于 2007 年 3 月 1 日以后本公司所制造的产品。

环保使用期限



此标志适用于在中国国内销售的电子信息产品，表示环保使用期限的年数。所谓环保使用期限是指在自制造日起的规定的期限内，产品中所含的有害物质不致引起环境污染，不会对人身、财产造成严重的不良影响。

环保使用期限仅在遵照产品使用说明书，正确使用产品的条件下才有效。

不当的使用，将会导致有害物质泄漏的危险。

产品中有毒有害物质或元素的名称及含量

部件名称	有毒有害物质或元素					
	铅(Pb)	汞(Hg)	镉(Cd)	六价铬(Cr(VI))	多溴联苯(PBB)	多溴二苯醚(PBDE)
外壳(壳体)	×	○	○	○	○	○
电子部件(印刷电路板等)	×	○	×	○	○	○
附件(电源线、交流适配器等)	×	○	○	○	○	○

○：表示该有毒有害物质在该部件所有均质材料中的含量均在 SJ/T11363-2006 标准规定的限量要求以下。

×：表示该有毒有害物质至少在该部件的某一均质材料中的含量超出 SJ/T11363-2006 标准规定的限量要求。

因根据现有的技术水平，还没有什么物质能够代替它。

For the USA

DECLARATION OF CONFORMITY Compliance Information Statement

Model Name : AR-3000SD
Type of Equipment : Audio Recorder
Responsible Party : Roland Corporation U.S.
Address : 5100 S.Eastern Avenue, Los Angeles, CA 90040-2938, U.S.A.
Telephone : (323) 890 3700

For the USA

FEDERAL COMMUNICATIONS COMMISSION RADIO FREQUENCY INTERFERENCE STATEMENT

This equipment has been tested and found to comply with the limits for a Class B digital device, pursuant to Part 15 of the FCC Rules. These limits are designed to provide reasonable protection against harmful interference in a residential installation. This equipment generates, uses, and can radiate radio frequency energy and, if not installed and used in accordance with the instructions, may cause harmful interference to radio communications. However, there is no guarantee that interference will not occur in a particular installation. If this equipment does cause harmful interference to radio or television reception, which can be determined by turning the equipment off and on, the user is encouraged to try to correct the interference by one or more of the following measures:

- Reorient or relocate the receiving antenna.
- Increase the separation between the equipment and receiver.
- Connect the equipment into an outlet on a circuit different from that to which the receiver is connected.
- Consult the dealer or an experienced radio/TV technician for help.

This device complies with Part 15 of the FCC Rules. Operation is subject to the following two conditions:

- (1) this device may not cause harmful interference, and
- (2) this device must accept any interference received, including interference that may cause undesired operation.

This equipment requires shielded interface cables in order to meet FCC class B limit.

Any unauthorized changes or modifications not expressly approved by the party responsible for compliance could void the user's authority to operate the equipment.

For Canada

CAN ICES-3 (B)/NMB-3 (B)

For Korea

사용자 안내문

기종별	사용자 안내문
B 급 기기 (가정용 방송통신기자재)	이 기기는 가정용(B 급) 전자파적합기기로서 주로 가정에서 사용하는 것을 목적으로 하며, 모든지역에서 사용할 수 있습니다.

For C.A. US (Proposition 65)

WARNING

This product contains chemicals known to cause cancer, birth defects and other reproductive harm, including lead.



Roland

