

Artecta ZigBee LED controller 5 CH A9916000

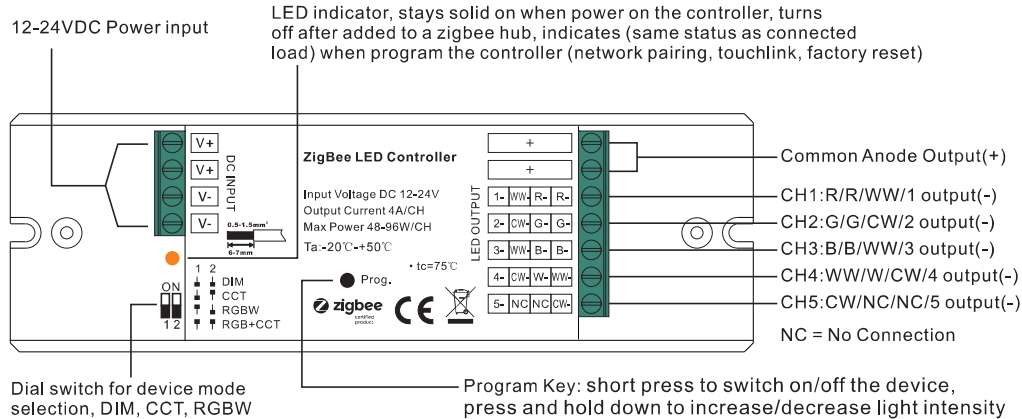

Important: Read All Instructions Prior to Installation

Function introduction



Dial switch for device mode selection, DIM, CCT, RGBW and RGB+CCT 4 modes are available, factory default is RGB+CCT mode

1) Under RGBW mode, W channel can only be turned on through color temperature control command (RGBW will be identified as RGB+CCT by zigbee). Color temperature control will mix RGB channels as 1 channel white and then make color tuning with the 4th channel white. Once turned on, the brightness of white channel will be controlled together with RGB channels.

2) Under RGB+CCT mode, RGB channels and tunable white channels are controlled separately, they can not be turned on and controlled at the same time.

Product Data

Input Voltage	Output Current	Output Power	Remarks	Size(LxWxH)	Ambient Temperature	Max. Casing Temperature
12-24VDC	4A/CH	48-96W/CH	Constant voltage	145x46.5x16mm	-20°C ~ +50°C	75°C

- 4 in 1 universal Zigbee LED controller based on latest ZigBee 3.0 protocol
- 4 different device modes DIM, CCT, RGBW and RGB+CCT in 1 controller, and selectable by dial switch
- Enables to control ON/OFF, light intensity, color temperature, RGB color of connected LED lights
- Can directly pair to a compatible ZigBee remote via Touchlink
- Supports self-forming zigbee network without coordinator
- Supports find and bind mode to bind a ZigBee remote
- Supports zigbee green power and can bind max. 20 zigbee green power remotes
- Compatible with universal Zigbee gateway or hub products
- Compatible with universal Zigbee remotes
- Waterproof grade: IP20

Safety & Warnings

- DO NOT install with power applied to device.
- DO NOT operate the dial switches for device mode selection with power applied to device.
- DO NOT expose the device to moisture.

Operation

1. Do wiring according to connection diagram correctly, please power off and power on the device once a device mode is selected so that the selected mode can be activated.

2. This ZigBee device is a wireless receiver that communicates with a variety of ZigBee compatible systems. This receiver receives and is controlled by wireless radio signals from the compatible ZigBee system.

3. Zigbee Network Pairing through Coordinator or Hub (Added to a Zigbee Network)

Step 1: Remove the device from previous zigbee network if it has already been added to, otherwise pairing will fail. Please refer to the part "Factory Reset Manually".

Step 2: From your ZigBee Controller or hub interface, choose to add lighting device and enter Pairing mode as instructed by the controller.

Step 3: Re-power on the device to set it into network pairing mode (connected light flashes twice slowly), network pairing mode lasts 15S (enters into touchlink mode after 15S), once timeout, repeat this step.

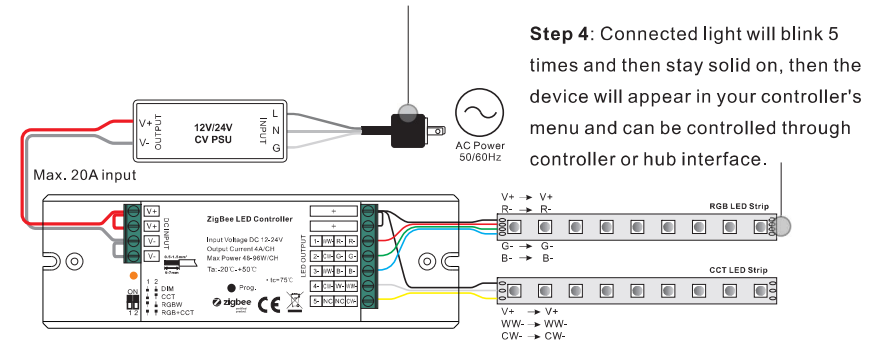

Step 4: Connected light will blink 5 times and then stay solid on, then the device will appear in your controller's menu and can be controlled through controller or hub interface.

4. TouchLink to a Zigbee Remote

Step 1: Method 1: Short press "Prog" button (or re-power on the device) 4 times to start Touchlink commissioning (lasts for 180S) immediately under any circumstances, once time out, repeat this step.

Method 2: Re-power on the device, Touchlink commissioning will start after 15S if it's not added to a zigbee network, 165S timeout. Or start immediately if it's already added to a network, 180S timeout. Once timeout, repeat the step.

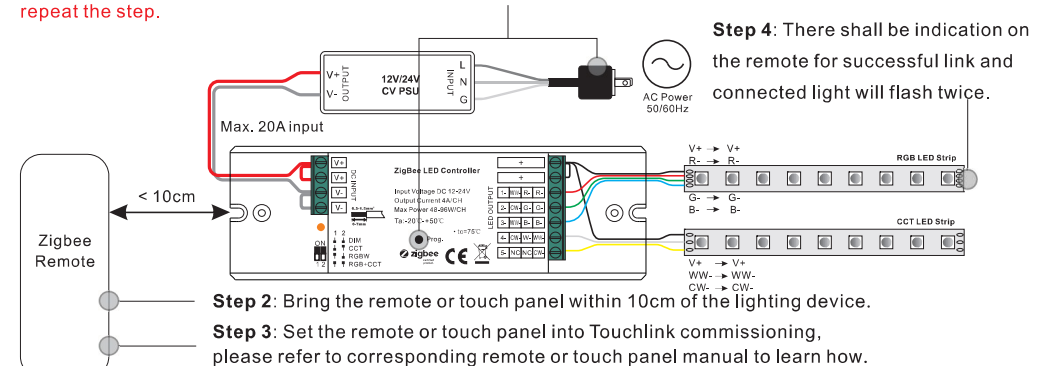

Step 2: Bring the remote or touch panel within 10cm of the lighting device.

Step 3: Set the remote or touch panel into Touchlink commissioning, please refer to corresponding remote or touch panel manual to learn how.

Note: 1) Directly TouchLink (both not added to a ZigBee network), each device can link with 1 remote.

2) TouchLink after both added to a ZigBee network, each device can link with max. 30 remotes.

3) For Hue Bridge & Amazon Echo Plus, add remote and device to network first then TouchLink.

4) After TouchLink, the device can be controlled by the linked remotes.

5. Removed from a Zigbee Network through Coordinator or Hub Interface

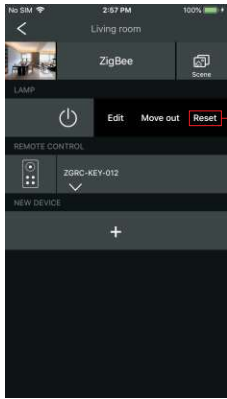

From your ZigBee controller or hub interface, choose to delete or reset the lighting device as instructed. The connected light blinks 3 times to indicate successful reset.

6. Factory Reset Manually

Step 1: Short press "Prog." key for 5 times continuously or re-power on the device for 5 times continuously if the "Prog." key is not accessible.

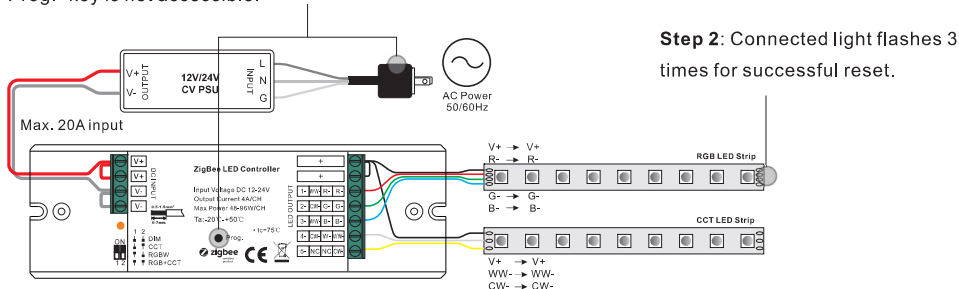

Note: 1) If the device is already at factory default setting, there is no indication when factory reset again.
2) All configuration parameters will be reset after the device is reset or removed from the network.

7. Factory Reset through a Zigbee Remote (Touch Reset)

Step 1: Re-power on the device to start TouchLink Commissioning, 180 seconds timeout, repeat this step.

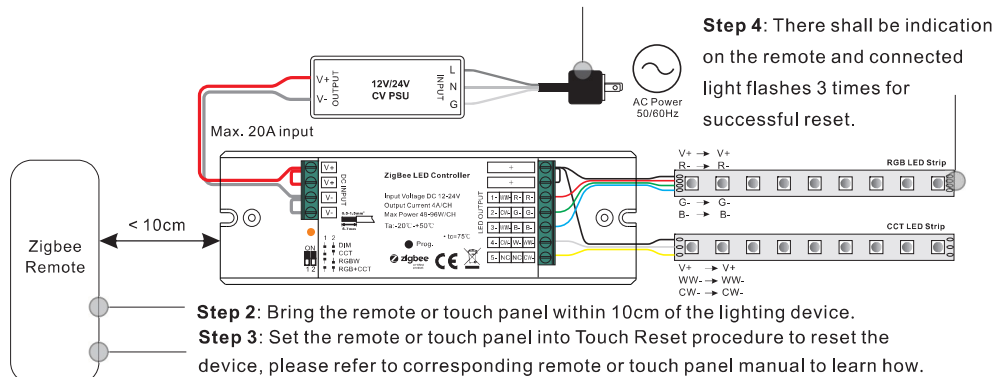

Note: Make sure the device already added to a network, the remote added to the same one or not added to any network.

8. Find and Bind Mode

Step 1: Short press "Prog." button 3 times (Or re-power on the device (initiator node) 3 times) to start Find and Bind mode (connected light flashes slowly) to find and bind target node, 180 seconds timeout, repeat the step.

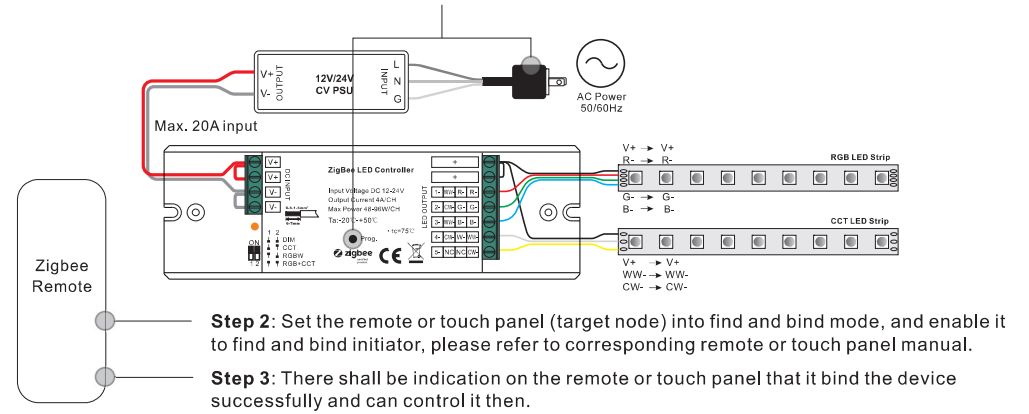

Note: Make sure the device and the remote or touch panel already added to the same Zigbee hub.

9. Learning to a Zigbee Green Power Remote

Step 1: Short press "Prog." button 4 times (Or re-power on the device 4 times) to start Learning mode (connected light flashes twice), 180 seconds timeout, repeat the step.

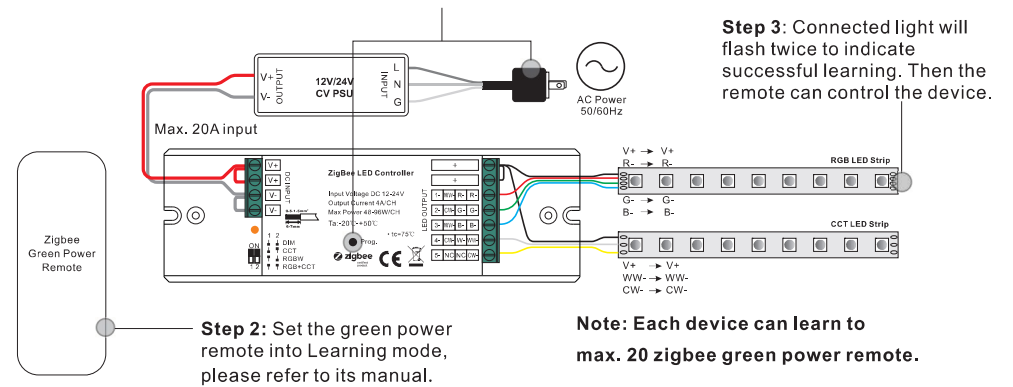

Note: Each device can learn to max. 20 zigbee green power remote.

10. Delete Learning to a Zigbee Green Power Remote

Step 1: Short press "Prog." button 3 times (Or re-power on the device 3 times) to start delete Learning mode (connected light flashes slowly), 180 seconds timeout, repeat the step.

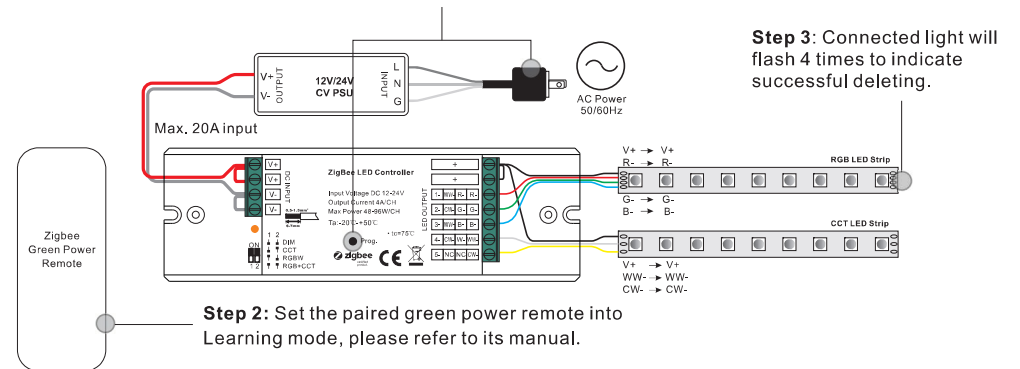

11. Setup a Zigbee Network & Add Other Devices to the Network (No Coordinator Required)

Step 1: Short press "Prog." button 4 times (Or re-power on the device 4 times) to enable the device to setup a zigbee network (connected light flashes twice) to discover and add other devices, 180 seconds timeout, repeat the step.

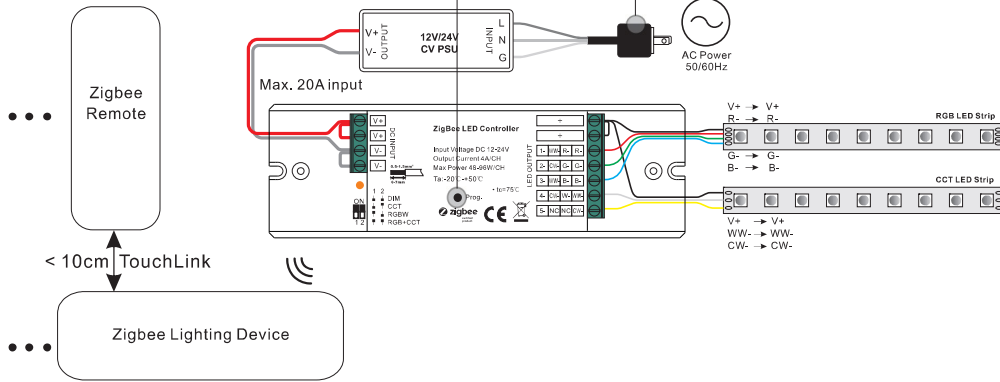

Step 2: Set another device or remote or touch panel into network pairing mode and pair to the network, refer to their manuals.

Step 3: Pair more devices and remotes to the network as you would like, refer to their manuals.

Step 4: Bind the added devices and remotes through Touchlink so that the devices can be controlled by the remotes, refer to their manuals.

Note: 1) Each added device can link and be controlled by max. 30 added remotes.

2) Each added remote can link and control max. 30 added devices.

12. ZigBee Clusters the device supports are as follows:

Input Clusters

- 0x0000: Basic
- 0x0003: Identify
- 0x0004: Groups
- 0x0005: Scenes
- 0x0006: On/off
- 0x0008: Level Control
- 0x0300: Color Control
- 0x0b05: Diagnostics

Output Clusters

- 0x0019: OTA

13. OTA

The device supports firmware updating through OTA, and will acquire new firmware from zigbee controller or hub every 10 minutes automatically.

Product Dimension

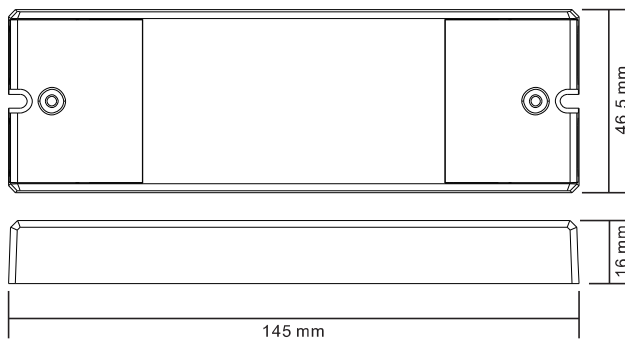

Wiring Diagram

1) RGB+CCT Mode

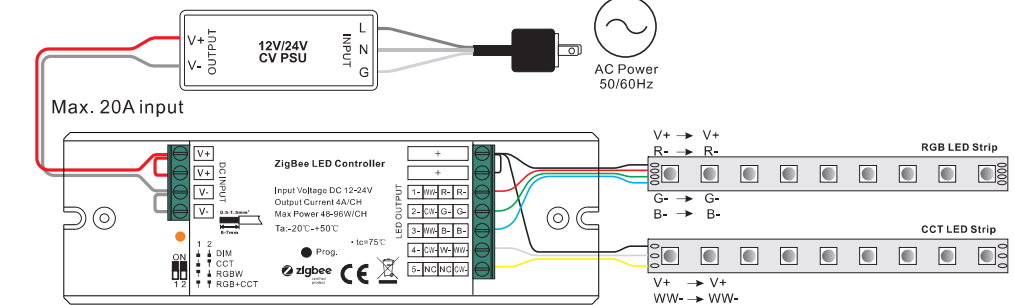

Note: please make sure the dial switches are at position for RGB+CCT mode as shown in above diagram.

2) RGBW Mode

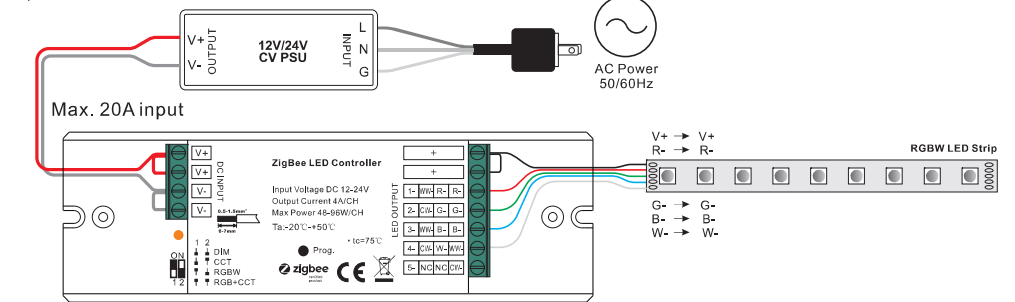

Note: please make sure the dial switches are at position for RGBW mode as shown in above diagram.

3) CCT Mode

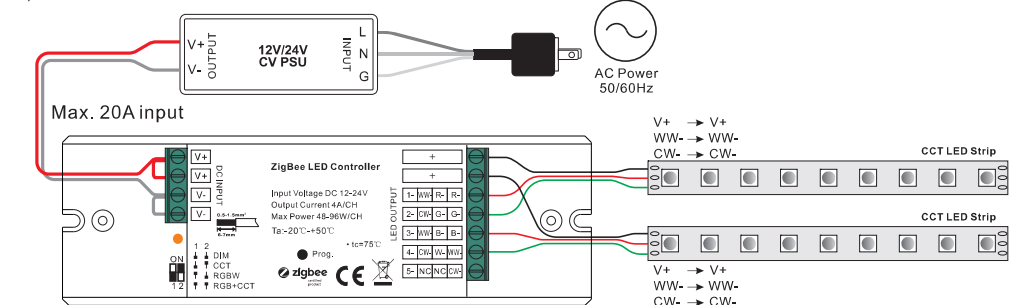

Note: please make sure the dial switches are at position for CCT mode as shown in above diagram.

4) DIM Mode

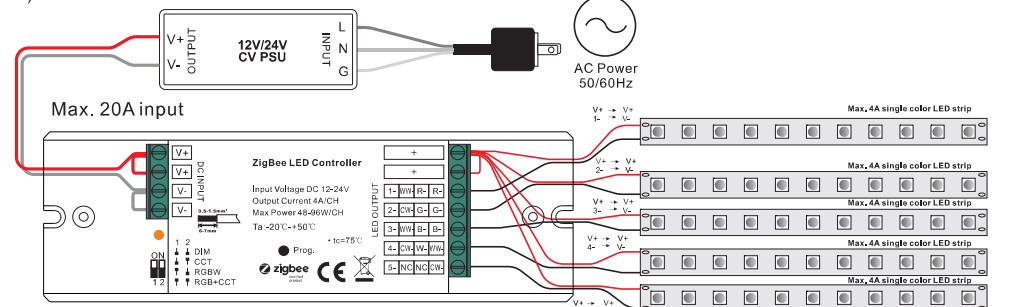

Note: please make sure the dial switches are at position for DIM mode as shown in above diagram.